

# Attenuators

## FIBER OPTIC CATALOG

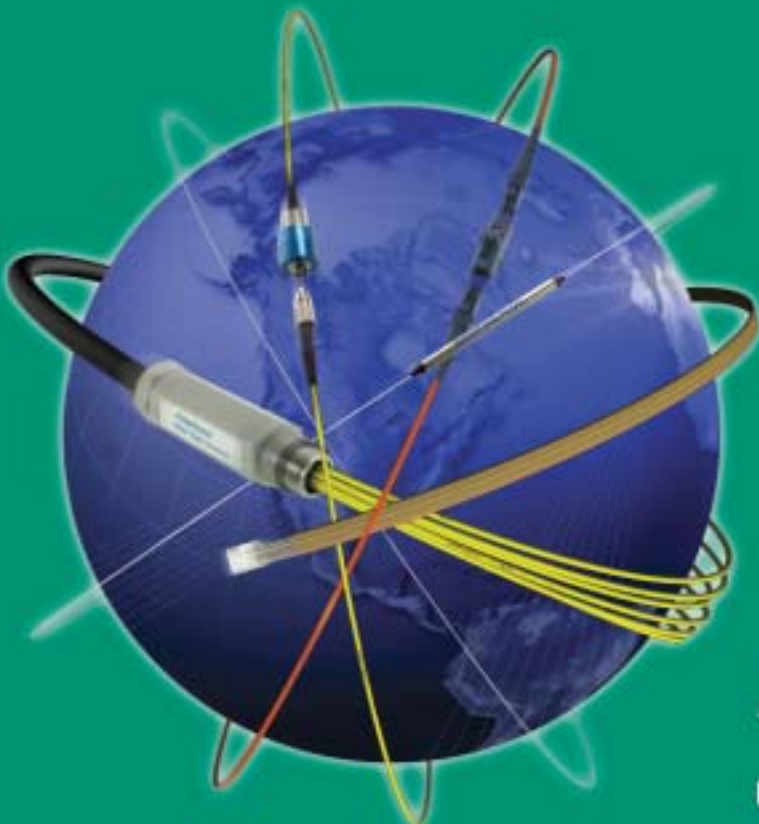

**Amphenol**<sup>®</sup>  
FIBER OPTIC PRODUCTS  
60 Years of Interconnect Knowledge

# Attenuators

Amphenol Fiber Optic Products attenuator product line consists of fixed and variable optical attenuators. An attenuator, by definition, is a device which precisely reduces an optical signal from point-to-point. The loss can be achieved through various technologies such as absorption, scattering, interference (thin film) filter, or air-gap. Amphenol has successfully developed three varieties of attenuators using select technologies to provide the best products in the market place.

- ▶ plug style (fixed) - absorption
- ▶ in-line (fixed) - scattering
- ▶ variable - air-gap

The most common use of the optical attenuator, whether fixed or variable, is in optical networks where erbium doped amplifiers are being used. Attenuators are used to adjust optical signal levels thereby increasing network flexibility and providing management of optical power.



Attenuator Family

Table of Contents	Page #
Introduction	1
Technology, Definitions, Testing	2
Plug Style Attenuators	3-4
Comparison Graphs	5
In-Line Attenuators	6
Variable Attenuators	7-8
Terminators	9
Polishing	10

Attenuation (dB) vs. Percent of Transmitted Power			
dB = 10 log (% transmission)			
dB	% of Power	dB	% of Power
0dB	100.00%	11dB	7.94%
1dB	79.43%	12dB	6.31%
2dB	63.10%	13dB	5.01%
3dB	50.12%	14dB	3.98%
4dB	39.81%	15dB	3.16%
5dB	31.62%	16dB	2.51%
6dB	25.12%	17dB	2.00%
7dB	19.95%	18dB	1.58%
8dB	15.85%	19dB	1.26%
9dB	12.59%	20dB	1.00%
10dB	10.00%		



## Technology, Definitions and Testing

Abr.	Key Concept	Units	Description & Definition
A	Attenuation	dB	Loss of power from input A = $10 \log (P1 / P0)$
$\Delta A$	Attenuation Tolerance	dB	The $\Delta$ between the marked attenuation value on a device and the actual attenuation
RL	Reflectance, Return Loss	dB	Ratio of reflected power back to any port
PDL	Polarization Dependent Loss	dB	The maximum attenuation variation over all input polarization states

## Comparison Graphs

### Flatness over Wavelength

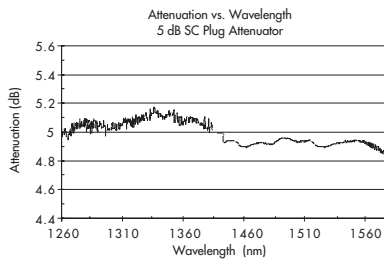

Plug Attenuator

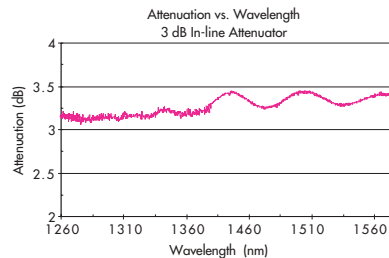

In-line Attenuator

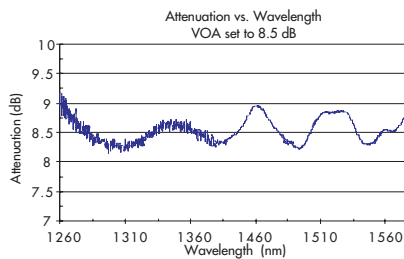

Variable Attenuator

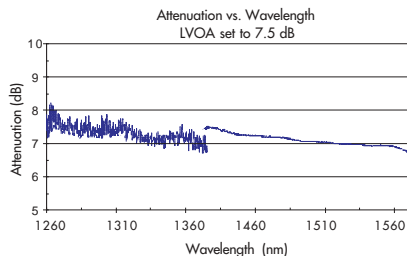

Linear Variable Attenuator

### Flatness over Temperature

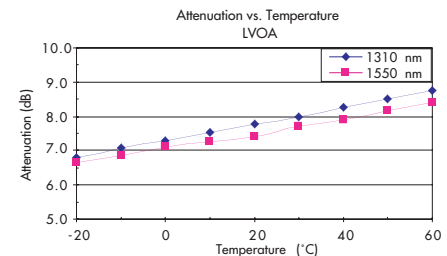
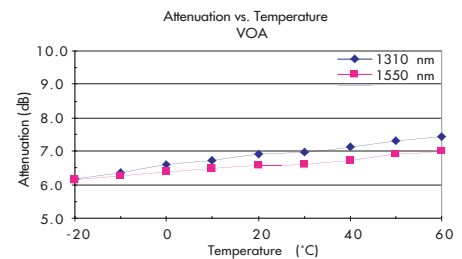
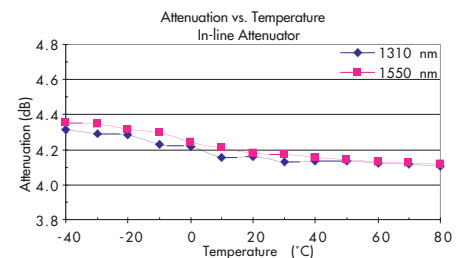
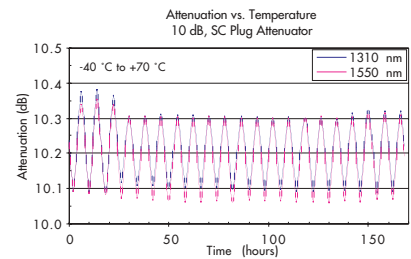

# Plug Style Attenuator

**Amphenol's Plug Style Attenuator** is a fixed optical attenuator often referred to as a build-out or pad style attenuator. The plug attenuator is compact in size, offers attenuation values from 0-20dB and is available in industry standard connector styles FC and SC with either flat or angle polish.

Optical attenuators have proven to be a critical component of any fiber optic network. By introducing an attenuator, you are able to adjust the transmission signal into the dynamic range of the receiver. This increases the life span of more expensive optical equipment and ultimately provides a clearer transmission signal. With a flat attenuation over temperature and the operating bandpass, Amphenol's 944 and 954 series plug attenuators are proven cost savers and perfectly suited for traditional telecommunications, CATV and private network applications.

Amphenol's plug style attenuators use light absorption technology as opposed to scattering. This eliminates the scattering of light into the fiber cladding that could be reflected back from the connector interface. With the short distance from connector end-face to end-face, the reflected light creates interferences that in turn create insertion loss variation as the wavelength changes. The light absorption technology has proven to be the superior technology for this compact design.

## Features

- ▶ Wavelength independent for multiple wavelength system compatibility
- ▶ Available in FC and SC configurations
- ▶ Polarization insensitive
- ▶ Compact plug style design easily fits into existing patch panels
- ▶ Available in 1 dB through 20 dB attenuation values
- ▶ Meets Telcordia GR-910 specifications



## Common Specifications

### Attenuation Values:

$\leq 5 \text{ dB} \pm 0.5 \text{ dB}$

$\geq 6 \text{ dB} \pm 10\%$  of nominal value

### Back Reflection/Return Loss:

Super polish:  $\leq -45 \text{ dB}$

Ultra polish:  $\leq -55 \text{ dB}$

Angle polish:  $\leq -65 \text{ dB}$

### Operating Temperature:

$-40 \text{ }^\circ\text{C}$  to  $80 \text{ }^\circ\text{C}$

### Operating Wavelengths:

1310/1550nm (center wavelength)

### Operating Bandpass:

1260 to 1360nm and 1430 to 1580nm

### PDL:

$\leq 0.2\text{dB}$

## Applications

- ▶ Telecom central office
- ▶ CATV head-end
- ▶ Data communications
- ▶ Test and Measurement

## Intermateability

The Amphenol FC and SC plug attenuators are mechanically intermateable with NTT type FC and SC products which conform to JIS C 5970 and JIS C 5973 respectively.

# Ordering Information

## Single Mode Plug Style Attenuators

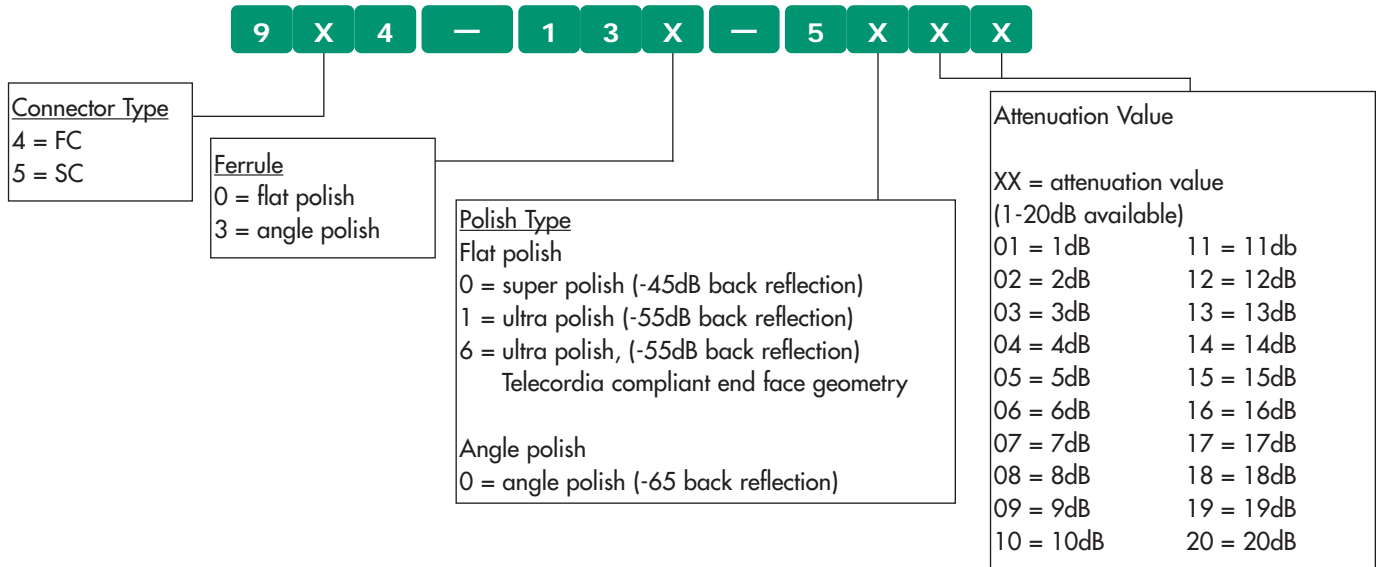

944-130-50XX

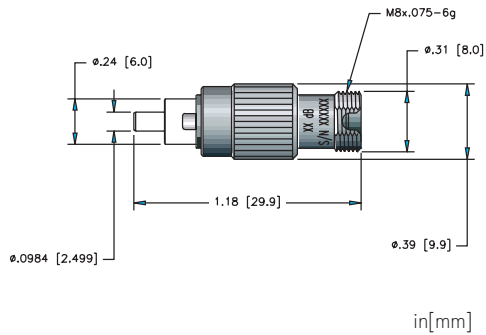

944-133-50XX

**8° Angle Polish**

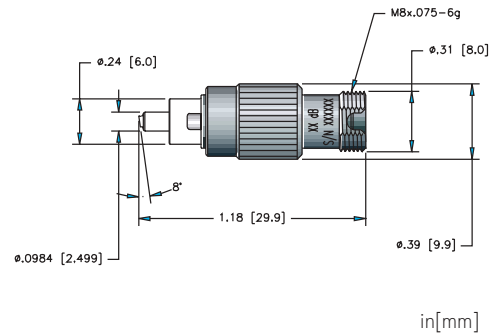

954-130-50XX

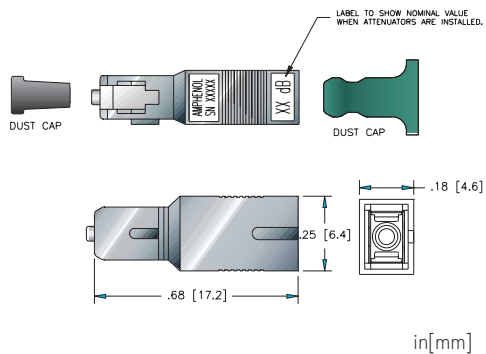

954-133-50XX

**8° Angle Polish**

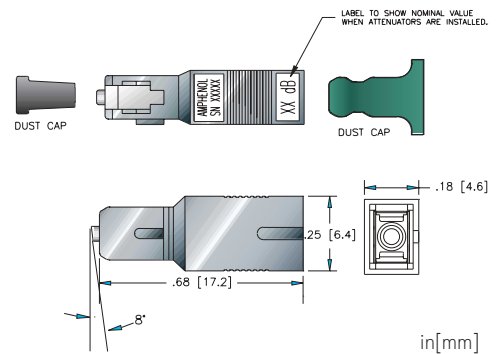

**Amphenol's 944 & 954 fixed plug style attenuators** are fully qualified to Telcordia GR-910, Issue 2, requirements. The all fiber construction is proven to be ideally suited for optical networks with both controlled and uncontrolled temperatures, where the source wavelength can vary due to ambient temperature. The attenuators are used in digital, sonet, and video optical networks.

## Plug Testing

InGaAsP/InP  
MLM Laser/LED  
Temperature  
(in degrees C)

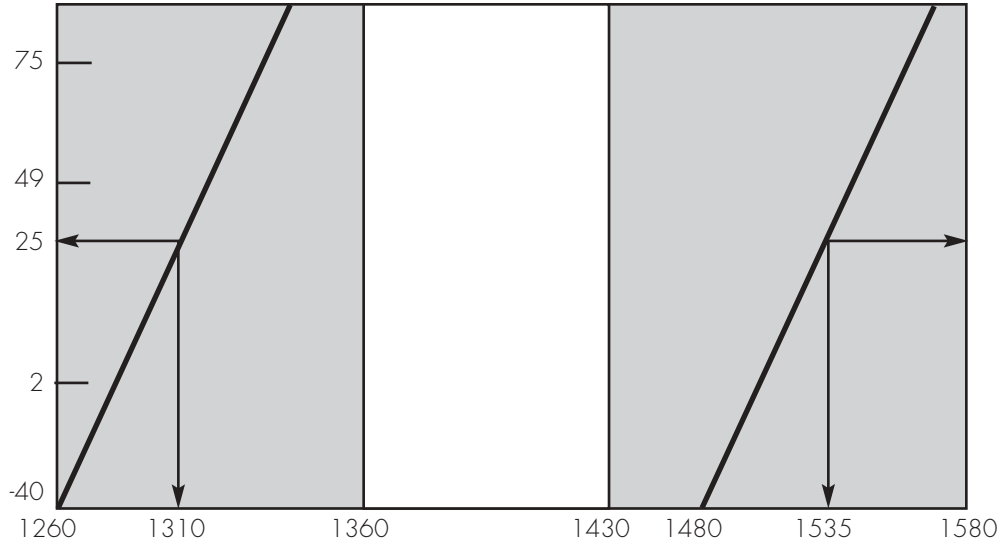

## Comparison Graphs

Operating Wavelength

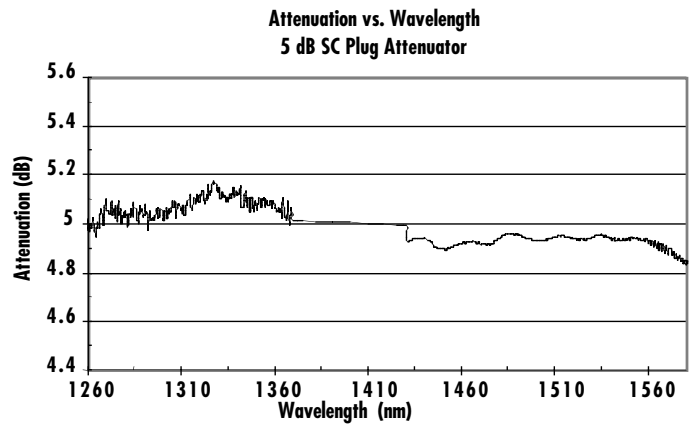

Temperature Cycling

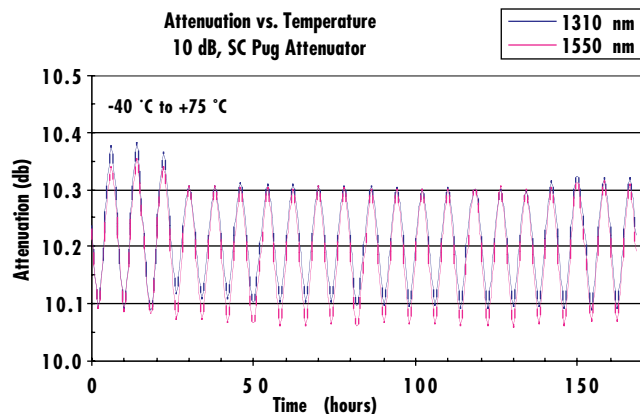



# 945 Series In-line Attenuators

**Amphenol's Fixed In-line Attenuators** provide a medium for adjusting the transmission signal. The slender packaging design is well suited for installation into OEM equipment. In-line attenuators are available with attenuation values ranging from 1-20 dB and can be terminated with any single mode connector or left unterminated for splicing.

Amphenol's in-line fixed attenuators are designed around the light scattering technology caused by offset fusion splicing. The scattered light is diffused out within 6" from the fused region thereby eliminating the interference effect and resulting in a flat wavelength response through a cost effective, highly repeatable manufacturing technique.

## Applications

- ▶ CATV networks
- ▶ Telecommunications networks
- ▶ Local/Wide Area Networks (LAN/WAN)
- ▶ Optical amplifiers & transceivers
- ▶ Test & Measurement instrumentation
- ▶ Signal monitoring devices

## Features

- ▶ Broadband performance
- ▶ Environmentally stable

## Ordering Information

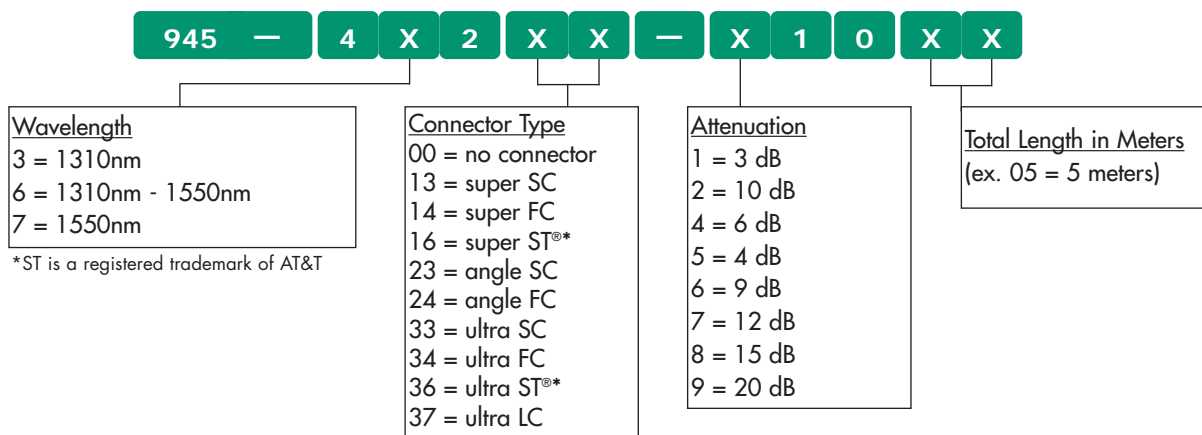

## Common Specifications

### Back Reflection/Return Loss:

- Unterminated:  $\leq -65$ dB
- Super polish:  $\leq -45$ dB (terminations only)
- Ultra polish:  $\leq -55$  dB (terminations only)
- Angle polish:  $\leq -65$ dB (terminations only)

**Fiber type:** 9/125µm single mode Corning SMF 28

**Operating temperature:** -20°C to +65°C

**Storage temperature:** -40°C to 75°C

**Operating wavelength:** 1310nm, 1550nm, and  
1310/1550nm = +/- 40nm

**Lead length:** 1.0 meter standard

3mm  
package

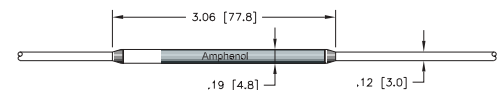

900 µm  
package

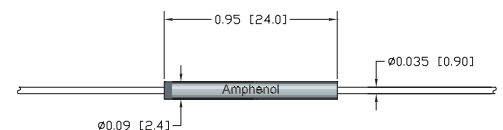

bare fiber  
package

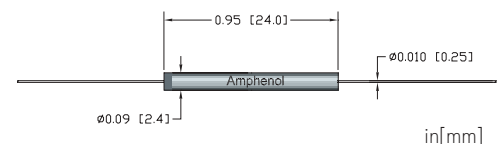

in[mm]

# 942 Single Mode Variable Attenuators

The Amphenol 942 series variable optical attenuators are passive in-line components, which precisely reduce the intensity of optical signals with minimum back reflection. The variable attenuators are available in both linear and non-linear design. Amphenol's variable attenuators are capable of meeting ultra low insertion loss (IL) due to the internal component design.

Amphenol's variable attenuators are manufactured using the air-gap technology where the attenuation value is changed as the air-gap is manually adjusted. This design utilizes fewer internal components compared to the competing technologies. No internal adhesives are used which result in a more stable product over time, temperature, humidity, and vibration as proven by thousands of field tested devices.

## Applications

- ▶ Telephone, long distance, Local Loop Networks (LLN)
- ▶ CATV headends
- ▶ Test and Measurement

## Features

- ▶ Low return loss
- ▶ Environmentally stable
- ▶ Proven angle PC connector based design eliminates bulk optic or thin film components
- ▶ Rugged packaging
- ▶ Single handed adjustment

## Linear Variable Attenuator



Amphenol's next generation variable attenuator offers a linear relationship between the attenuation value and adjustment setting. The linear response provides easy management of optical signals in a multi-channel network. The automatic reset feature insures that the device cannot be damaged due to improper usage.

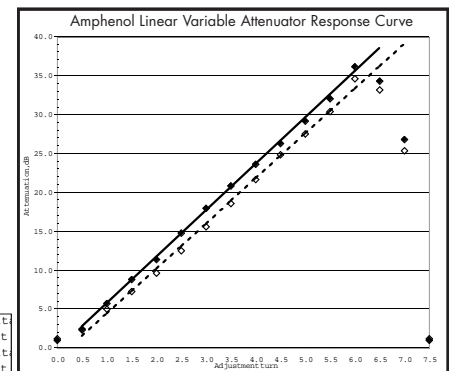

## Variable Attenuator



Amphenol's original variable attenuator is compact in design and provides the ability to achieve low attenuation values. The rugged package is designed for installation into uncontrolled environmental conditions.

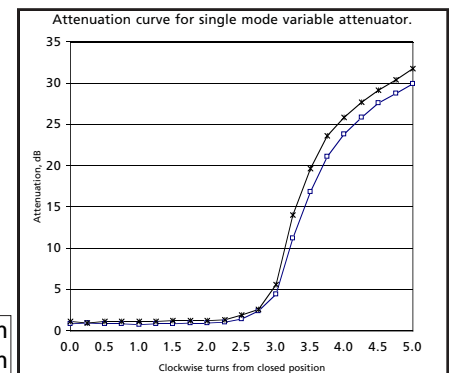



# 942 Single Mode Variable Attenuator

	Linear Variable Attenuator		Variable Attenuator
	Grade A	Grade B	Grade A
Attenuation Range	2-30dB	1-30dB	2-40dB
Resolution	< 0.25dB	< 0.25dB	< 0.25dB
PDL	≤ 0.5dB	≤ 0.5dB	≤ 0.5dB
Return Loss	-45dB super polish, -55dB ultra polish, -65dB angle polish		
Terminations	FC, SC, or ST style connectors with super, ultra, or angle polish performance, LC available in super or ultra polish		
Operating Wavelengths	1260-1360nm and 1430-1580nm		
Operating Temperature	-20 °C to 65 °C		
Storage Temperature	-40 °C to + 75 °C		
Lead Length	1.0 meter standard for both sides		
Cable Type	3mm PVC type or OFNR cable with Corning SMF 28 single mode fiber		

## Ordering Information

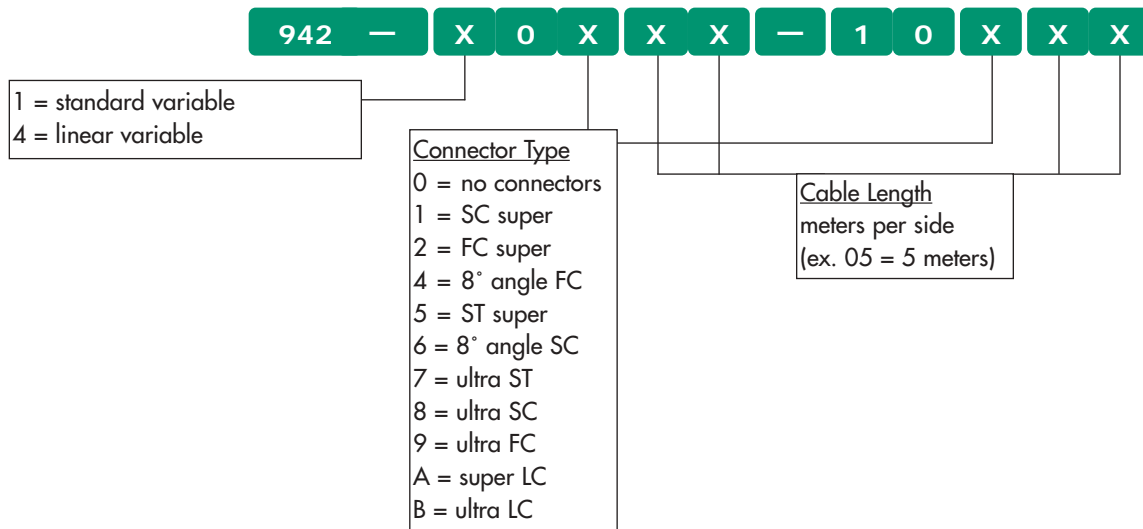

### 942 Series Linear Variable Attenuator

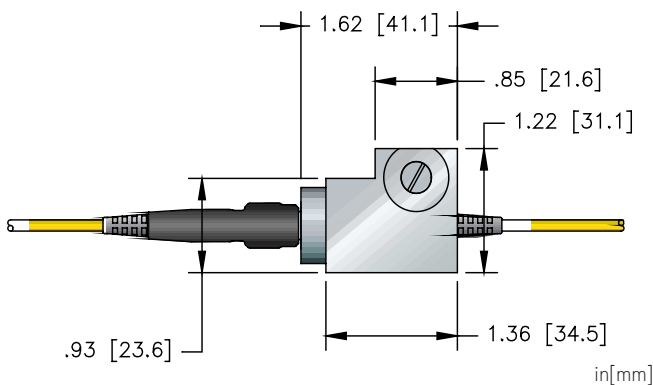

### 942 Series Variable Attenuator

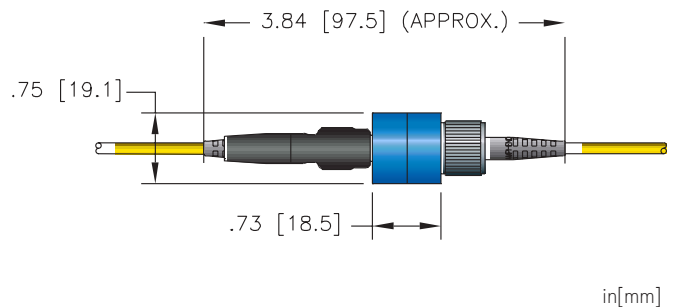

# Terminators

Amphenol optical terminators are designed to reduce the back reflection from open connectors. This increases network performance and reduces stray laser light that can potentially cause eye injury. With increased power levels being utilized in every market sector, there is an ever increasing demand for optical terminators.

## Applications

- ▶ Analog and CATV
- ▶ Non-reflective termination of unused ports
- ▶ Bi-directional transmission systems
- ▶ High bit-rate telecommunication systems

## Features

- ▶ Termination without use of index-matching materials
- ▶ Light absorption technology is utilized to terminate optical power insuring long term reliability and temperature stability
- ▶ Available in FC and SC connector styles



Terminator Family

## Common Specifications

### Back Reflection/Return Loss:

Super polish	-45dB
Ultra polish	-55dB
Angle polish	-65dB

**Operating Temperature:** -40 °C to + 85 °C

**Operating Wavelengths:** 1260-1360nm and 1430-1580 nm

### Intermateability:

The Amphenol 954 series SC connectors and adapters are mechanically and optically intermateable with NTT SC type products and conform to JIS C 5973. SC duplex connectors and adapters conform to ANSI VX3T9.3 SC specifications and are intermateable.

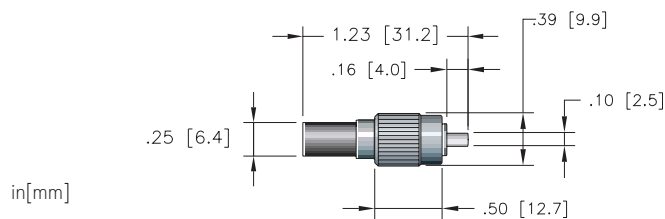

### FC Terminators

**944-999-2000** = super, -45dB

**944-999-2002** = ultra, -55dB

**\*944-999-2003** = ultra, -55dB

\*(Telcordia Issue 3 end face geometry)

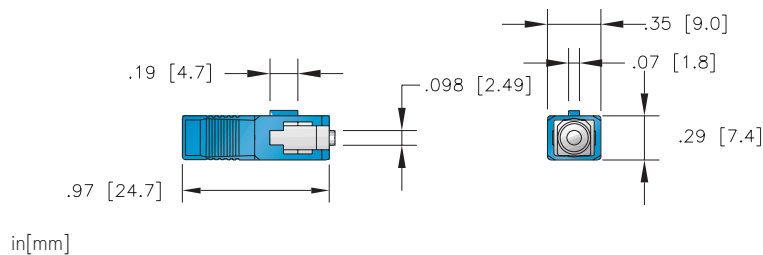

### SC Terminators

**954-999-2000** = super, -45dB

**954-999-2002** = ultra, -55dB

**954-999-2003** = angle, -65dB

**\*954-999-2005** = ultra, -55dB

\*(Telcordia Issue 3 end face geometry)

# Polishing

Amphenol's termination expertise dates back to the first industry standard connector (SMA), over 25 years ago. As new fiber optic connectors have entered the industry, Amphenol has carefully selected the most robust and reliable connectors to participate in its design and development. Our in depth understanding of connector design, and having the complete control of connector materials, make Amphenol terminations some of the best in the industry.

We offer a comprehensive line of single mode connector styles, which can be terminated onto the in-line fixed attenuators or either of the variable attenuators. Such connector options include SC, FC, LC, LX.5<sup>®\*</sup>, ST<sup>†</sup>, MT-RJ, and MTP<sup>††</sup>(MPO). In addition, we offer the FC and SC type fixed plug attenuators.

All too often passive components are viewed as commodities, and are evaluated strictly on price. Quality often tends to be viewed as an understood element and not evaluated seriously. While passive components may be one of the least expensive components in the network, no chain is stronger than its weakest link. When considering the function of an optical attenuator it is critical to consider not

only the attenuation value but also the long-term reliability of the device. For these reasons Amphenol has made a substantial investment of engineering time and long-term testing into designing the highest quality termination procedures to ensure that the attenuators meet the tightest industry standards over time and exposure to various environmental conditions.

In the manufacturing of optical attenuators the fiber end face is a key element to providing a product which will perform as needed over time. In order to produce highly reliable attenuators, there are a number of physical characteristics of the ferrule end face to be addressed. Many of these issues have been thoroughly outlined by such standards organizations as IEC, EIA/TIA and Telcordia. They include acceptable parameters for insertion loss, return loss, radius of curvature, apex offset and fiber height. Other issues that attribute to long term reliability are ferrule/fiber fit, ferrule concentricity, and ferrule surface defects. The following diagrams illustrate the critical components of a fiber optic termination. We pride ourselves in having a controlled manufacturing process which yields a polish that meets or exceeds the tightest industry specifications.

**Misalignment** - Fiber core alignment is critical to a passive component's ability to transmit light. The main causes of misalignment are typical mechanical issues associated with poor connectors or poor fiber: ferrule concentricity, hole tolerances, fiber eccentricity, and variations in core diameter.

**Surface Defects** - The most commonly overlooked aspect of a termination is the surface of the ferrule. Often, if it meets insertion loss and return loss specifications, it is assumed good. Visual defects are one of the most common causes of latent failures. Scratches, pits, and chips in the ferrule end face can change over time, becoming more pronounced and migrating to critical areas of the fiber core, thus affecting performance. They are also a prime source for deposits of dust, moisture, and other contaminants. In order to insure the best possible network performance over time, it is imperative to have a ferrule finish that is free of any defects in region A, near the core, and meet a strict criteria of gradual allowances for regions B & C.

**Radius of Curvature** - The end face of the ferrule is given a specific radius during the polishing process. This radius provides the basis for ensuring that both fibers make contact. Both the apex offset and fiber heights are dependent on the radius of curvature being within the predetermined parameters.

**Fiber Height** - Physical contact of the fiber is necessary for proper light transfer. The fiber has allowable protrusion limits, as well as strict undercut limits. These limits are based on mathematical calculation of the radius of curvature. If the fiber is too high, damage to the end face may occur. If it is too low, the physical contact will never occur, causing increased attenuation.

**Apex Offset** - Physical contact connectors feature a radius at the end face. The peak of the radius is known as the apex. The relationship from the apex to the 'perfect' center of the ferrule is known as the apex offset. Strict control of this specification is mandatory in order to precisely control the distance of each fiber from the surface of the ferrule, and to ensure physical contact upon mating.

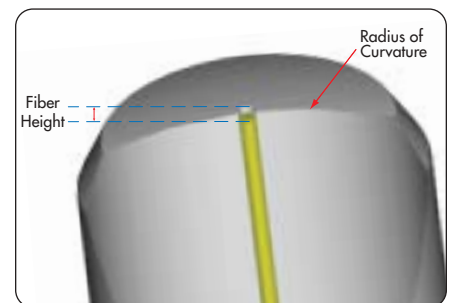
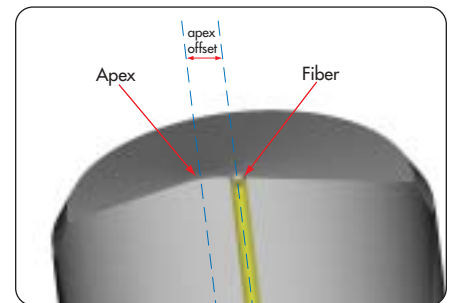

Amphenol offers three standard, single-mode polishing options, which are differentiated through the ferrule polish and back reflection performance. The following table provides our standard performance criteria. In addition, Amphenol is able to provide custom solutions to meet our customer's demands.

Connector Type	Polish Type	Insertion Loss		Return Loss	
		Typical	Maximum	Typical	Maximum
SC, FC, LC, & ST	Super (SPC)	0.18dB	0.5dB	-52dB	-45dB
	Ultra (UPC)	0.14dB	0.3dB	-61dB	-55dB
	Angle (APC)	0.23dB	0.5dB	-70dB	-65dB
MT-RJ	Ultra (UPC)	0.20dB	0.50dB	N/A	-35dB
MPO	Standard Angle	0.25dB	0.75dB	-55dB	-55dB
	Angle (APC)	0.15dB	0.35dB	-55dB	-55dB

**Note:** Telcordia compliant terminations guaranteed to meet 100% of Telcordia GR-326, Issue 3, end-face geometry requirements. Custom end-face geometry specifications available upon request.

\* LX.5 is a registered trademark of ADC Telecommunications, Inc.

† ST is a registered trademark of AT&T.

†† MTP is a registered trademark of US Conec, Ltd.

# Amphenol Corporation Website

[www.amphenol.com](http://www.amphenol.com)

Worldwide Service & Support

---

## AMERICAS

### Amphenol Corporation

Wallingford, CT, U.S.A.  
Phone: +1-203-265-8900  
E-mail: [aphinfo@amphenol.com](mailto:aphinfo@amphenol.com)

### Amphenol Canada Corp.

Scarborough, Ontario, Canada  
Phone: +1-416-291-4401  
E-mail: [matitl@amphenolcanada.com](mailto:matitl@amphenolcanada.com)

### Amphenol Interconnect Products Corporation

Endicott, NY, U.S.A.  
Phone: +1-607-754-4444  
E-mail: [sales@aipc.fabrik.com](mailto:sales@aipc.fabrik.com)

### Amphenol Spectra-Strip Operations

Hamden, CT, U.S.A.  
Phone: +1-203-281-3200  
Email: [sales@spectra-strip.com](mailto:sales@spectra-strip.com)

### Amphenol RF Division

Danbury, CT., U.S.A.  
Phone: 1-203-796-2000  
E-mail: [104704.2600@compuserve.com](mailto:104704.2600@compuserve.com)

### Amphenol do Brasil LTDA (AIPC)

Cacapava, SP, Brazil  
Phone: +55-12-253-2502  
E-mail: [sales@aipc.fabrik.com](mailto:sales@aipc.fabrik.com)

### Amphenol Corp. Argentina

Buenos Aires, Argentina  
Phone: +54-11-4341-4565  
E-mail: [amphenol\\_argentina@compuserve.com](mailto:amphenol_argentina@compuserve.com)

### Amphenol do Brasil LTDA.

Sao Paulo - SP, Brazil  
Phone: +55-11-5185-2881  
E-mail: [amphenol@amphenol.com.br](mailto:amphenol@amphenol.com.br)

### Amphenol Corp. Mexico

CP 11560 Mexico D.F. Mexico  
Phone: +52-5-254-7283  
E-mail: [amphenol\\_mex@compuserve.com](mailto:amphenol_mex@compuserve.com)

### Times Fiber Communications, Inc.

Wallingford, CT, U.S.A.  
Phone: 1-203-265-8500  
E-mail: [aphinfo@amphenol.com](mailto:aphinfo@amphenol.com)

## EUROPE

### Amphenol European Sales Operations

Houten, The Netherlands  
Phone: +31-30-6358-000  
E-mail: [info@amphenol-nl.com](mailto:info@amphenol-nl.com)

### Amphenol RF/Coax Europe

Houten, The Netherlands  
Phone: +31-30-6358-026  
E-mail: [info@amphenol-nl.com](mailto:info@amphenol-nl.com)

### Amphenol Gessellschaft GmbH

Wien, Austria  
Phone: +43-1-895-1511  
E-mail: [info@amphenol-at.com](mailto:info@amphenol-at.com)

### Amphenol Iberica

Madrid, Spain  
Phone: +34-91-673-2235  
E-mail: [info@amphenol-it.com](mailto:info@amphenol-it.com)

### Amphenol Italia S.p.A.

Lainate (Milano), Italy  
Phone: +39-2-939-04192  
Email: [info@amphenol-it.com](mailto:info@amphenol-it.com)

### Amphenol Scandinavia

Upplands Vasby, Sweden  
Phone: +46-8-594-10040  
E-mail: [info@amphenol-se.com](mailto:info@amphenol-se.com)

### Amphenol Limited

Whitstable, Kent, Great Britain  
Phone: +44-227-773-200  
E-mail: [info@amphenol.co.uk](mailto:info@amphenol.co.uk)

### Amphenol Ltd. (AIPC-UK)

I Tech Division  
Glasgow, Renfrewshire  
Scotland, Great Britain  
Phone: +44-1-475-888-898  
E-mail: [114776.1446@compuserve.com](mailto:114776.1446@compuserve.com)

### Spectra-Strip Ltd.

Romsey Hampshire  
Great Britain  
Phone: +44-1794-517-575  
E-mail: [sales@spectra-strip.com](mailto:sales@spectra-strip.com)

### Amphenol Socoapex S.A.

Dole Cedex, France  
Phone: +33-3-8482-9400  
E-mail: [webmaster@amphenol-socapex.com](mailto:webmaster@amphenol-socapex.com)

## ASIA & R.O.W.

### Amphenol Japan. K.K.

Chiyoda-ku, Tokyo, Japan  
Phone: +81-3-3263-5611  
E-mail: [info@amphenol.co.jp](mailto:info@amphenol.co.jp)

### Amphenol Daeshin Electronics

Precision Co., Ltd.  
Kyungki-Do, Korea  
Phone: +82-32-680-3800  
E-mail: [info@amphenol.co.kr](mailto:info@amphenol.co.kr)

### Amphenol East Asia Ltd.

Kowloon, Hong Kong  
Phone: +852-2699-2663  
E-mail: [info@amphenol.com.hk](mailto:info@amphenol.com.hk)

### Amphenol Taiwan Corp.

Taoyuan, Taiwan  
Phone: +886-3-379-5677  
E-mail: [info@amphenol.com.tw](mailto:info@amphenol.com.tw)

### Amphenol South China

Bao An, Shenzhen, China  
Phone: +86-755-719-9622  
E-mail: [+info@amphenol.com.cn](mailto:+info@amphenol.com.cn)

### Shenzhen (China) Office

Shenzhen, China  
Phone: +86-755-368-3575  
E-mail: [info@amphenol.com.cn](mailto:info@amphenol.com.cn)

### Guangzhou Amphenol

Electronics Communications  
Guangzhou, China  
Phone: +86-20-3869-8808  
E-mail: [Thomang@gecamphenol.com](mailto:Thomang@gecamphenol.com)

### Singapore Office

Phone: +65-294-2128  
E-mail: [info@amphenol.com.sg](mailto:info@amphenol.com.sg)

### Amphetrnix Limited

Bhosari Industrial Area  
Pune, India  
Phone: +91-20-7120363  
E-mail: [sales@amphenol-in.com](mailto:sales@amphenol-in.com)

### Amphenol Australia Ltd.

Keysborough Vic, Australia  
Phone: +61-3-8796-8888  
E-mail: [info@amphenol.com.au](mailto:info@amphenol.com.au)

---

# Amphenol<sup>®</sup>

FIBER OPTIC PRODUCTS

## Fiber Optic Products

[www.amphenol-fiberoptics.com](http://www.amphenol-fiberoptics.com)  
[sales@amphenol-fiberoptics.com](mailto:sales@amphenol-fiberoptics.com)  
1-800-944-6446