

Singlemode Cable Assemblies

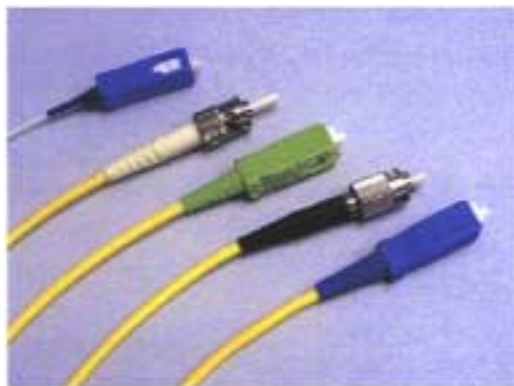

FEATURES

- Available in default, ultra and angle polish configurations to meet all fibre optic cable assembly requirements
- Utilise high quality connectors
- 100% optically tested for insertion loss and return loss
- Individually packaged and labeled.
- Machine polished to ensure consistency and quality.
- Custom engineered cable assemblies are available

POLISHING SPECIFICATIONS (General)

Termination Type	Insertion Loss (Maximum)	Return Loss (Maximum)	Operating Temperature
Default FC, SC, ST	0.3 dB	-50 dB	-40°C to +85°C
Ultra FC, SC, ST	0.3 dB	-55 dB	-40°C to +85°C
Angle FC, SC, ST	0.3 dB	-65 dB	-40°C to +85°C

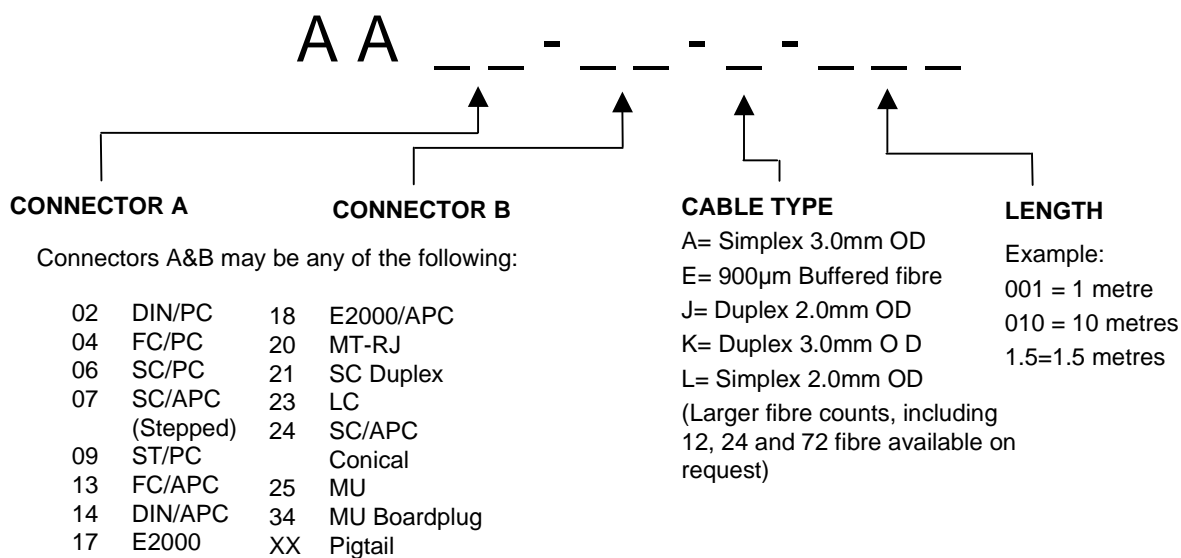

If a connector requires **Ultra** polishing, simply place a U after the connector part number. Example 04U is FC Ultra polish

EXAMPLE

AA04-07-A-005

Singlemode simplex 3.0mm cord with FC/PC terminated on one end and SC/APC on the other end.

AA06U-13-E-1.5

Singlemode 900µm buffered fibre with SC/UPC terminated on one end and FC/APC on the other end.

Customised options are also available including devices, breakout kits, packaging and labeling. Please don't hesitate to contact Amphenol to discuss your requirements.