

Amphenol[®]

Interconnect Solutions for Hybrid & Electric Vehicles



电动汽车/混合动力汽车

《《《 高压连接与配电解决方案

Amphenol

► | Amphenol

is one of the largest manufacturers of interconnect products in the world. The company designs, manufactures and markets electrical, electronic and fiber optic connectors, coaxial and flat-ribbon cable, and interconnect systems. Amphenol has long been the accepted leader in providing quality connectors and interconnect systems to the Industrial, Military and Telecommunication markets.

► | 安费诺集团

是全球规模最大的互连产品生产商之一。Amphenol专注于电气、电子、光纤连接器、同轴扁平带状电缆以及互连系统的设计、制造和销售。长期以来，Amphenol因其品质优良的连接器和互连系统产品，受到工业、军事和通信领域的高度认可，并在市场中占据着主导地位。

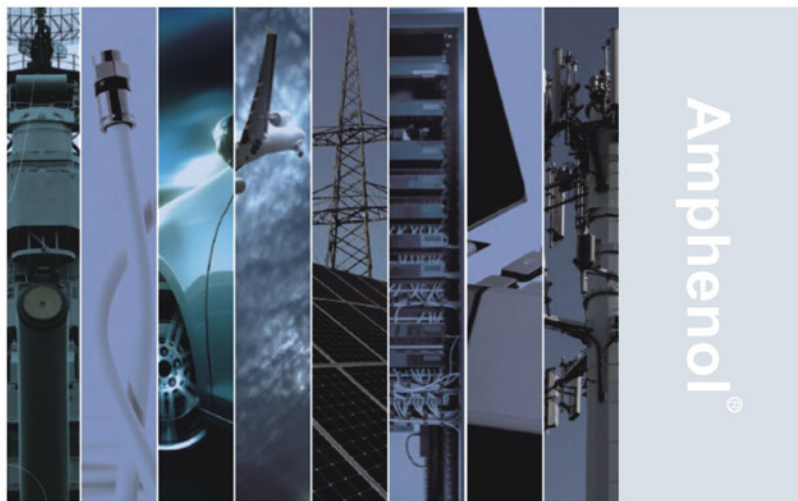



Amphenol Industrial Products Group

The Amphenol Industrial Products Group (AIPG), a division of the Amphenol Corporation, is a prominent manufacturer of cylindrical connectors known around the world. Amphenol Industrial's product lines consist of rectangular, standard miniature, fiber optic, EMI/EMP filter, and a variety of special application connectors.

Manufacturing connectors since 1932, we take pride that the Amphenol Industrial Products Group is the undisputed leader in interconnect systems for harsh environment applications. Innovations like our RADSOK® contact technology can provide roughly 50% more current through the same size pin. Connectors utilizing this RADSOK® technology will outperform similar products in the market hands down.

The Sidney, NY facility, nestled at the foothills of the Catskill Mountains, is over 307,000 square feet. This complex houses over 1,000+ employees incorporating state-of-the-art manufacturing technologies. The facility is both ISO9001 certified and qualified to MIL-STD-790 requirements.

► | 安费诺工业产品事业部 (简称:安费诺工业部)

安费诺工业产品事业部是安费诺集团全球八大事业部中最重要的事业部之一。她是全球恶劣环境互连系统解决方案的不可争议的领导者，其工业连接器的设计和生产技术水平长居全球领先地位。

安费诺工业产品线包括圆形、矩形、标准微型、光纤、EMI/EMP滤波器以及各种特殊应用连接器。

安费诺工业产品事业总部位于美国纽约州，面积超过30,700平方英尺，拥有雇员1000余人，拥有最先进的生产技术，其创新的RADSOK®专利端子技术提供比市场上同等大小的普通端子多50%~100%的载流能力，运用此技术的安费诺连接器轻易地超越了市场上的同类产品。



Amphenol Technology (Zhuhai)

Established in 2007, Amphenol Technology (Zhuhai) Co., Ltd. is a manufacturing facility for the Amphenol Industrial Products Group, which serves a number of industrial markets, included but not limited to Factory Automation, Transportation, Heavy Equipment, Alternative Energy, Oil & Gas, Server/Data Comm and Power Distribution.

Amphenol Technology (Zhuhai) Co., Ltd. covers an area of 28,470m² and is equipped with CNCs, plating, injection molding and assembly workshops. This plant specializes in the design and manufacturing of industrial connectors featuring high power, high density inserts, medium to high voltage electrical properties, and harsh environment applications.

With industry leading engineering, design and manufacturing expertise, Amphenol Technology (Zhuhai) Co., Ltd. has earned more than 10 utility patents on its innovative interconnects. Many of the products produced have been certified by independent standards including UL, IEC/TUV, ATEX, IECEx and MA. The facility is also certified to ISO 9001, ISO 14001 and TS 16949.

► | 安费诺科技（珠海）

安费诺科技(珠海)有限公司是由美国安费诺集团独资建立、隶属于安费诺工业产品事业部在中国的生产工厂之一。工厂成立于2007年，位于珠海市金湾区三灶镇科技园，占地面积28470平方米，雇员600人以上。工厂主设CNC车间、电镀车间、注塑车间、装配车间等。公司拥有强大的设计研发能力和先进的生产技术，目前已获得10余项实用新型专利证书。工厂通过了ISO 9001、ISO 14001和TS 16949等相关认证。

安费诺科技(珠海)有限公司专注于工业连接器及电缆组件的研发生产与销售，产品以大电流、高密度信号、中/高电压、耐各种极端恶劣环境及高可靠性为特色，广泛应用于重型设备、轨道交通、新能源车辆、石油天然气/采矿、服务器/数据通信、智能电网、机器人/自动化控制等众多领域。

Amphenol

Interconnect Solutions for Hybrid and Electric Vehicles



► | Interconnect Solutions for Hybrid and Electric Vehicles

A progression away from gasoline and towards a new automotive energy market, including hybrid and electric driven vehicles (HEV) has many demanding electrical requirements. The electrical systems used on HEVs require higher amperages and voltages, smaller component footprints and more reliable and safer operation.

With over eighty years of experience in the interconnect industry, Amphenol Industrial Products Group (AIPG) brings its design, manufacturing, and innovation to the hybrid and electric market. As an undisputed global leader of interconnect solutions for harsh environments, AIPG has solutions to solve any technical challenge. Whether it's a new connector design or one of our existing products, an over molded or mechanically terminated cable assembly, complex harness, or complete electrical packaging solution, AIPG has the expertise to satisfy all HEV needs.

► | 电动和混合动力车辆电气互连解决方案

随着传统汽油转向新的汽车能源市场的发展，包括混合动力和纯电动车辆(HEV)在内，对电气系统都有着苛刻的要求。这些电气系统都要求有更大的电流电压、更紧凑的空间结构和更安全可靠的操作性能等。

今天，拥有超过80年连接器设计制造经验的安费诺工业产品集团（简称安费诺工业部），将她设计、制造和创新的产品带入了这个飞速发展的市场。作为全球不可争议的恶劣环境电气互连系统解决方案的领导者，安费工业部拥有各种互连解决方案来迎接任何技术上的挑战。不论是现有的产品或是新产品的的设计、是热塑成型或是线夹锁合的电缆组件、复杂线束，或是完整的电气集成方案，安费诺工业部都有相应的技术和产品来满足混合动力和纯电动车辆市场的任何需要。



Where in the HEV Ecosystem our Products are Found 产品应用领域



安费诺高压电气系列产品应用指南

Application Guide for Amphenol High Voltage Product Series

设备 Equipment	输入/输出接口 Interface of Input/Output	规格/对应产品 Specification/Product			产品详情页 Page Number
高压配电箱 PDU	电驱动空调 Electric driven air conditioner	2W,25A~80A;600VDC,Shielded (2芯、25A~80A、600VDC、带屏蔽)	Power: ePower-Lite series 电源: ePower-Lite 系列	SurLok Plus 	SurLok Plus 系列 P1-P2
	电加热器 Electric heater	2W,25A~80A;600VDC,Shielded (2芯、25A~80A、600VDC、带屏蔽)	Power: ePower-Lite series 电源: ePower-Lite 系列		
	电动助力转向 Electric power steering system(EPAS)	2W,25A~80A;600VDC,Shielded (2芯、25A~80A、600VDC、带屏蔽)	Power: ePower-Lite series 电源: ePower-Lite 系列		
	电机控制器 Motor controller	2W<250A;600VDC,Shielded (2芯、<250A、600VDC、带屏蔽)	UPC series/系列 ePower series/系列	UPC 	UPC系列 P3-P5
	电控制冷 Electric control refrigeration system	2W<250A;600VDC,Shielded (2芯、<250A、600VDC、带屏蔽)	UPC series/系列 ePower series/系列		
	电池 Battery	1W,<250A,750VDC, unshielded/shielded (1芯、<250A、750VDC、不带或带屏蔽)	SurLok Plus series/系列		
	充电机 Charger	1W,<250A,750VDC, unshielded/shielded (1芯、<250A、750VDC、不带或带屏蔽)	SurLok Plus series/系列		
	信号控制 Signal controller	20W~48W, 5A~23A, 250VAC,unshielded (20W~48W, 5A~230A, 250VAC,不带屏蔽)	Signal: UPT系列 信号: UPT系列	ePower 	ePower系列 P6
动力电池组 Power battery pack	充电输入 Charging input	2W, 25A~80A;600VDC,Shielded (2芯、25A~80A、600VDC、带屏蔽)	ePower-Lite series/系列	ePower-Lite 	ePower-Lite 系列 P7-P8
	DC/DC电压输入 DC/DC voltage input	2W, 25A~80A;600VDC,Shielded (2芯、25A~80A、600VDC、带屏蔽)	ePower-Lite series/系列		
	直流充电输入 DC charging input	2W<250A;600VDC,Shielded (2芯、<250A、600VDC、带屏蔽)	UPC series/系列 ePower series/系列		
	主电源输出 Main power output	2W<250A;600VDC,Shielded (2芯、<250A、600VDC、带屏蔽)	UPC series/系列 ePower series/系列		
	电池内部连接 Battery internal connection	客户定制 Custom design	SurLok Plus series/系列 Custom Design for Flex Busbar 定制铜排等		
DC/DC变压器 DC/DC transformer	直流输入 DC input	2W, 25A~80A;600VDC,Shielded (2芯、25A~80A、600VDC、带屏蔽)	ePower-Lite series/系列	UPT 	UPT系列 P9-P11
驱动电机 Drive motor	交流输入 AC input	3W<250A, 600VDC, Shielded (3芯、<250A、600VDC、带屏蔽)	UPC series/系列 ePower series/系列		
逆变器 Invertor	交流输出 AC output	3W<250A, 600VDC, Shielded (3芯、<250A、600VDC、带屏蔽)	UPC series/系列 ePower series/系列		
	直流输入 DC input	2W<250A;600VDC,Shielded (2芯、<250A、600VDC、带屏蔽)	UPC series/系列 ePower series/系列		
车载充电机 Vehicle-mounted charger	交流输入 AC input	3W, 25A~80A; 600VDC, Shielded or unshielded (3芯、25A~80A; , 600VDC、屏蔽或非屏蔽)	ePower-Lite series/ePower-Lite系列	Flexible Busbar 	Flexible Busbar系列 P12
	直流输出 DC output	2W, 25A~80A;600VDC, Shielded (2芯、25A~80A;、600VDC、带屏蔽)			

SurLok Plus™ 系列



The SurLok Plus™ compression lug is a field installable, highly reliable alternative to common compression lugs. Using industry standard crimp, screw, and busbar termination options, thus eliminating the need to purchase special torque tools.

Amphenol's SurLok Plus™ is an environmentally sealed version of our original SurLok™ but available in smaller sizes, and features a quick lock and press-to-release design. Incorporating the latest R4 RADSOK® Technology, SurLok Plus™ is a compact, quick mating, and robust product line.

SurLok Plus是一款现场安装型、高性能压连接器（压线鼻子）。采用行业标准的压接、锁螺丝和汇流排接线，而不需要特殊的扭力工具。

SurLok Plus是安费诺原有SurLok的环境密封版本，但尺寸上可以做到更小，同时具有快速锁定和按压解锁的特点。SurLok Plus采用了最新的R4 RADSOK®技术，是一款结构紧凑、快速插拔和坚固耐用的产品。

► | Features & Benefits 性能特点:

- **R4 RADSOK® Technology**
R4 RADSOK®端子技术
- **IP67 rated**
防水等级IP67
- **Touch Proof**
防触电设计
- **Quick lock and press-to-release design**
快速锁定和按压解锁设计
- **“Keyway” design to prevent incorrect mating**
“键位”设计防止误配
- **360° rotating plug**
360°旋转插头
- **Various termination options (Threaded, Crimp, Busbar)**
多种接线方式（螺纹、压接、汇流排）
- **Compact robust design**
紧凑而坚固的结构设计

Technical Data 技术参数			
Contact Size 端子尺寸	5.7mm (120A) 8.0mm (200A) 10.3mm (300A)	IP Rating 防水等级	IP67
Current Rating 额定电流	120A~300A	Protection 防护等级	Touch Proof 防触电
Operating Voltage 工作电压	1000V AC/DC	Flammability 阻燃等级	UL 94-V0
Operating Temp 工作温度	-40°C to 125°C	Locking 锁定方式	Spring Locking 弹簧锁

锁螺丝接线

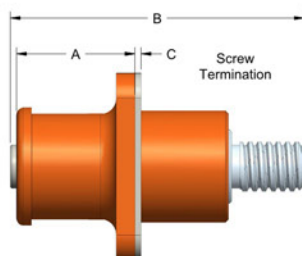

Size	Screw Termination		
	A	B	C
5.7mm	16	37.7	1
8.0mm	19	46.2	1
10.3mm	25.8	55.9	0.3

压接接线

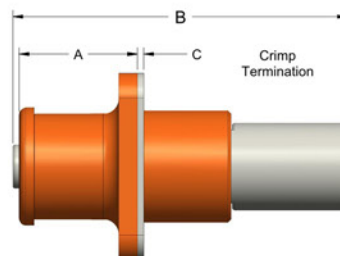

Size	Crimp Termination		
	A	B	C
5.7mm	16	40.7	1
8.0mm	19	53.7	1
10.3mm	25.8	69.2	0.3

汇流排接线

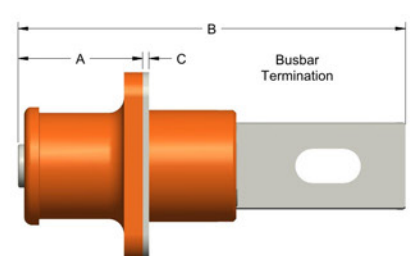

Size	Busbar Termination		
	A	B	C
5.7mm	16	47.6	1
8.0mm	19	62.2	1
10.3mm	43	68.8	0.3

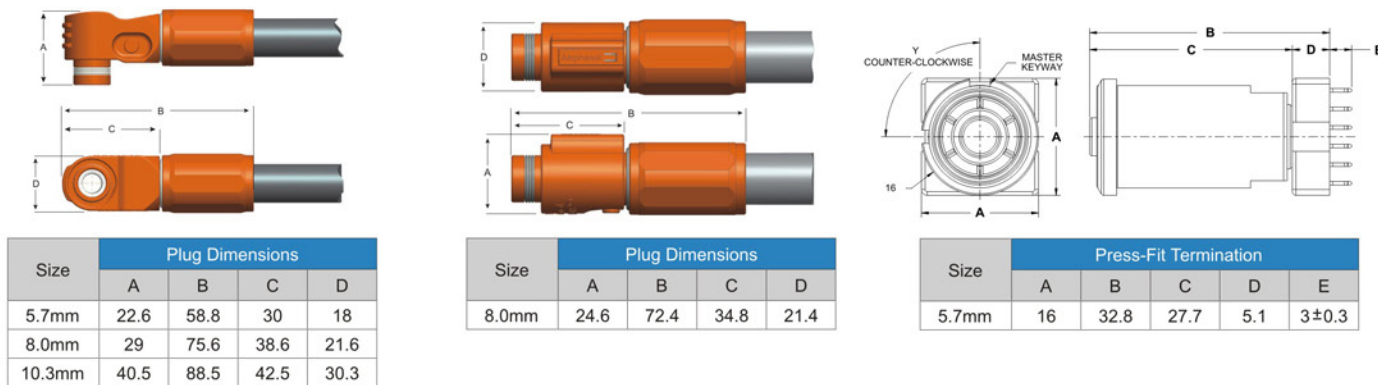

► Ordering Information 订购选型指南

PLUG 插头

Product Series: SurLok Plus™ 产品系列	Plug 插头		RADSOK®Size 端子尺寸	Applicable Cable Size 适用接线尺寸		Backshells 尾附件	Sealing 密封	Connector Color 连接器颜色	Keyway(Omit for no Keyway) 键位 (Omit 为无键位)		EMI (电磁屏蔽)	HVIL (高压互锁)						
SLP	P	Right Angle Plug 90°弯头插头	A	5.7mm	16	16mm²:100 Amps	B	W/Backshells 带尾附件	S	IP67 sealed (W/Grommet&O-Rings) 防水等级IP67(带密封垫圈或O型圈)	O	Orange (黄色)	0	90°	E	EMI	H	HVIL
					25	25mm²:120 Amps					B	Black (黑色)	1	180°				
			B	8.0mm	35	35mm²:150 Amps					2	60°						
					50	50mm²:200 Amps												
	IP	Straight Plug 直插头	C	10.3mm	70	70mm²:300 Amps	N	W/O Backshells(For Overmolding Only) 不带尾附件 (仅热塑模)	N	Non-Sealed 非密封	R	Red (红色)	3	120°				
					85	85mm²:350 Amps							4	150°				
			D	12mm	12	120mm²:400 Amps												
					E	14mm							18	185mm²:500 Amps				

Receptacle 插座

Product Series: SurLok Plus™ 产品系列	Receptacle 插座		RADSOK®Size 端子尺寸	*Applicable Cable Size 适用接线尺寸		Termination Style 接线类型	Panel Mount 面板安装	Sealing 密封	Connector Color 连接器颜色	Keyway(Omit for no Keyway) 键位 (Omit 为无键位)		EMI (电磁屏蔽)	HVIL (高压互锁)					
SLP	R	Receptacle (W/O Keyway) 插座 (不带键槽)	A	5.7mm	16	16mm²:100 Amps	B	Busbar (汇流排)	P	IP67 sealed (W/Grommet & O-Rings) 防水等级 IP67(带密封垫圈或O型圈)	O	Orange (黄色)	0	90°	E	EMI	H	HVIL
					25	25mm²:120 Amps					B	Black (黑色)	1	180°				
			B	8.0mm	35	35mm²:150 Amps					2	60°						
					50	50mm²:200 Amps												
	IR	Receptacle (W/ Keyway) 插座 (带键槽)	C	10.3mm	70	70mm²:300 Amps	C	Crimp (压接)	N	W/O Flange 无法兰盘	N	Non-Sealed 非密封	R	Red (红色)	3	120°		
					85	85mm²:350 Amps									4	150°		
			D	12mm	12	120mm²:400 Amps												
					E	14mm									18	185mm²:500 Amps		

*Applicable cable size is only for crimping termination
适用接线范围仅针对于压接接线类型

UPC 系列



UPC (Ultimate Power Connector) is a plastic power connector series especially designed to be used in the hybrid electric vehicle market. The 2-pole and 3-pole connectors incorporate the patented RADSOK® technology for higher amperage, lower T-rise and voltage drop, and less resistance. RADSOK's twisted grid configuration allows for up to 50% more current to pass through the same size pin, while providing increased reliability and cycle durability, as well as lower mating forces.

The compact, plastic shell structure is light weight with a small footprint, has continuous power at 250 A or 400 A, and is field installable and repairable. These attributes make UPC robust and the interconnect of choice for the EV and Hybrid markets.

UPC 是一个专为混合动力车辆市场应用而特别设计的塑胶大电流连接器。产品有2芯和3芯结构，采用了安费诺专利RADSOK® 端子技术，使其能承载更大的电流，具有低温升、低电压降和低阻抗的性能特点。RADSOK端子扭曲的网格结构比同等大小的端子可多承载50%以上的电流，同时增强了可靠性和耐久性，也降低了插拔力。

UPC紧凑的塑胶外壳结构兼具重量轻和体积小的特点，其连续电流达到250A或400A，可进行现场安装和维修，特别适合电动和混合动力车辆的电气互连应用。

Features & Benefits 性能特点:

- **Plastic shell, light weight**
塑料外壳、重量轻
- **Compact design for space considerations with Evs**
紧凑的结构更适合空间局限的电动车市场
- **Wide amperage range (250-400A)**
承载电流范围宽 (250-400A)
- **Low mating/un-mating force** 低插拔力
- **Durability: 500 mating cycles minimum**
耐插拔最少500次
- **Touch-Proof (UL 2251)** 防触电设计
- **UL 94V-0** 阻燃标准
- **HVIL** 高压互锁
- **EMI (60db/100M)** 防电磁干扰
- **IP67 when mated** 连接后的防水等级为 IP67
- **RoHS Compliant** 符合无铅标准

Technical Data 技术参数			
Current Rating 额定电流	Up to 400A (250A max 9.1mm w /50mm2 cable)	Test Voltage (sea level) 测试电压	3000V AC RMS
Contact Size 端子尺寸	9.1mm /12mm RADSOK	Operating Temperature 工作温度	-40°C to 125°C
Operating Voltage 工作电压	1000V	Durability 耐插拔	500 (Min) Mating Cycles 最少500次
Flammability 阻燃性	IP67(Mated)	Touch-Proof 防触电	UL 2251
Waterproof 防水等级	360° (60db/100M)	HVIL 高压互锁C	Integrated 集成
EMI 防电磁干扰	UL 94V-0	Recommended Torque 推荐扭矩	M5: 6 ~ 8N.M

2-Pole Receptacle 2芯插座

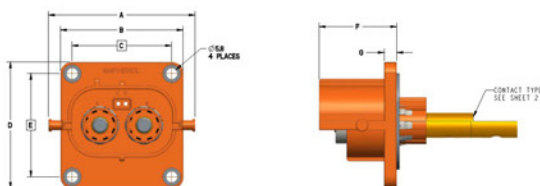

Size	Receptacle Dimensions						
	A	B	C	D	E	F	G
9.1mm	76.6	64	52	66	54	40.5	6.5

2-Pole 90° Plug 2芯直角 (90°) 插头

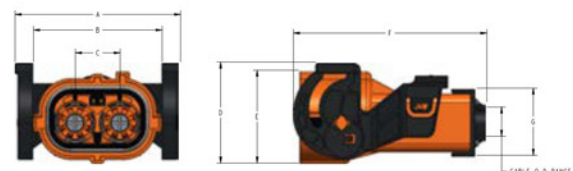

Size	2-Pole Plug Dimensions							Cable O.D Range
	A	B	C	D	E	F	G	
9.1mm	85	66	23	51.9	47.8	99.4	34.5	Ø15-17

3-Pole Receptacle 3芯插座

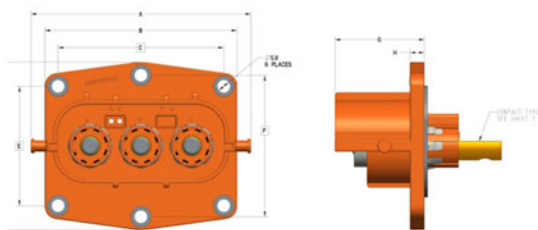

Size	Receptacle Dimensions							
	A	B	C	D	E	F	G	H
9.1mm	100	87	75	76	54	64	40.5	6.5

2-Pole Plug 2芯直插头

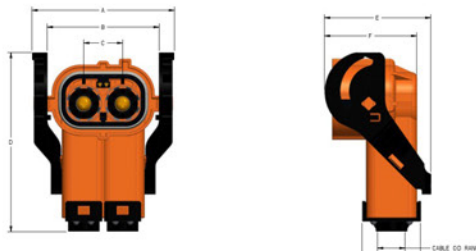

Size	Plug Dimensions							Cable O.D Range
	A	B	C	D	E	F	G	
9.1mm	64	66	23	106	63	54	34.5	Ø15~16

3-Pole Straight Plug 3芯直插头

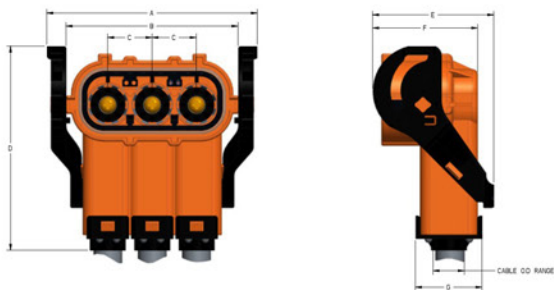

Size	Plug Dimensions							Cable O.D Range
	A	B	C	D	E	F	G	
9.1mm	109	89	23	106	63	54	34.5	Ø15~16

3-Pole 90° Plug 3芯直角 (90°) 插头

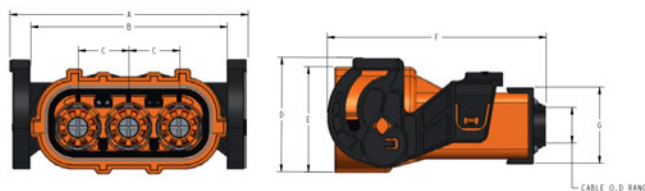

Size	3-Pole Plug Dimensions							Cable O.D Range
	A	B	C	D	E	F	G	
9.1mm	108	89	23	51.9	47.8	99.4	34.5	Ø15~17

Cut-Out Panel Layout of 2-Port(2芯插座面板开孔尺寸)

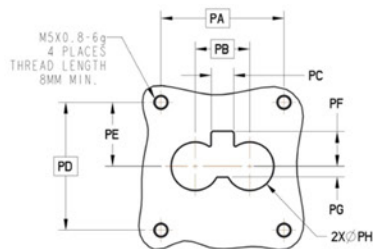

Size	Cut-Out Panel Dimensions							
	PA	PB	PC	PD	PE	PF	PG	PH
9.1mm	52	23	9.5	54	27	14.7	4.5	22.5

Cut-Out Panel Layout of 3-Port(3芯插座面板开孔尺寸)

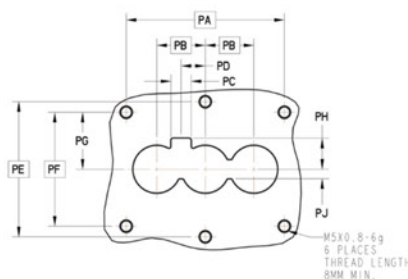

Size	Cut-Out Panel Dimensions								
	PA	PB	PC	PD	PE	PF	PG	PH	PJ
9.1mm	75	23	9.5	11.5	64	54	27	14.7	4.5

▶ 2芯插座汇流排接线类型

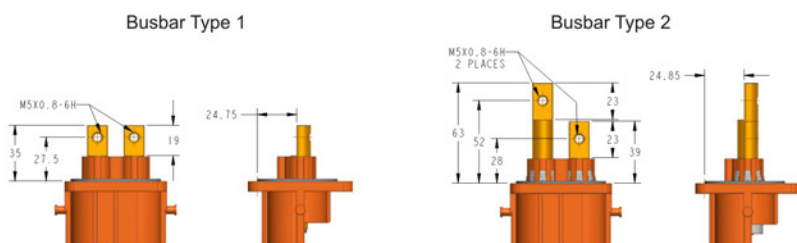

▶ 3芯插座汇流排接线类型

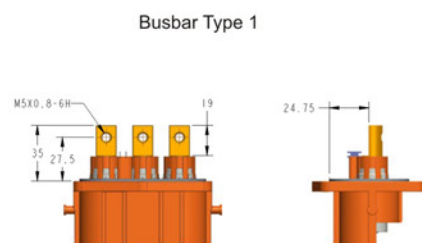

Codings 编码

2-Pole Receptacle 2芯插座编码

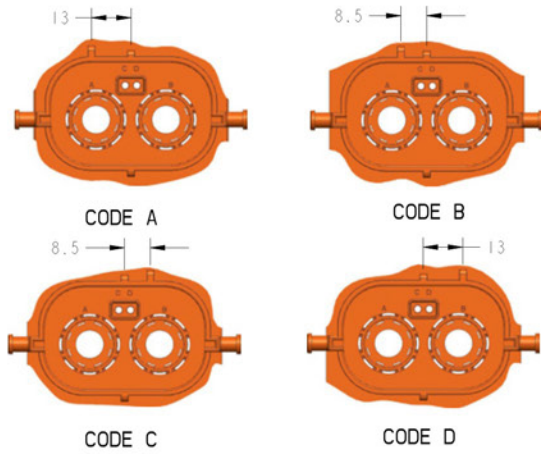

3-Pole Receptacle 3芯插座编码

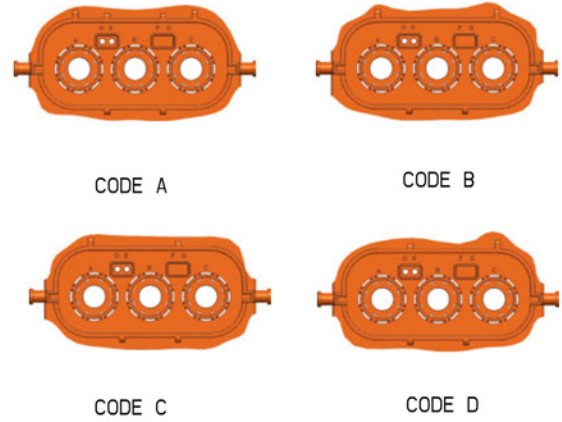

Ordering Information 订购选型指南

Plug 插头

Product Series: UPC 产品系列	Connector Type 产品类型	RADSOK® Contact Size 端子尺寸	Pole Number 芯数	Coding Selection 编码选择	HVIL Selection 高压互锁选择	EMI Selection 电磁屏蔽选择	Crimp Wire Size 压接线号			
UPC	P 90° Angular Plug 90° 弯头插头	01	9.1mm	2	2-Pole 2芯	A Code A	L HVIL 带高压互锁	S W/ Shielding Shell 带屏蔽外壳	1	35mm² (9.1mm Only)
		02	12.0mm	3	3-Pole 3芯	B Code B	N No HVIL 不带高压互锁	N W/O Shielding Shell 不带屏蔽外壳	2	50mm² (9.1mm Only)
					C Code C			3	70mm² (12.0mm Only)	
					D Code D			4	95mm² (12.0mm Only)	

Receptacle 插座

Product Series: UPC 产品系列	Connector Type 产品类型	RADSOK® Contact Size 端子尺寸	Pole Number 芯数	Coding Selection 编码选择	HVIL Selection 高压互锁选择	EMI Selection 电磁屏蔽选择	Contact Type 端子类型			
UPC	R Box Mount Receptacle (盒式安装插座)	01	9.1mm	2	2-Pole 2芯	A Code A	L HVIL 带高压互锁	S W/ Shielding Shell 带屏蔽外壳	1	Busbar type 1 汇流排类型1
		02	12.0mm	3	3-Pole 3芯	B Code B	N No HVIL 不带高压互锁	N W/O Shielding Shell 不带屏蔽外壳	2	Busbar type 2 汇流排类型2
						C Code C				
						D Code D				

ePower 系列



This series of connectors is designed for the demanding requirements of hybrid, electric vehicles, and utility truck electrical systems, operating at 800VDC to 1000VDC with 200A, 400A, and 700A continuous current ratings. The product incorporates the patented RADSOK® technology for higher amperage, lower T-rise, less resistance and mating force. Meantime, it offers a 40% smaller footprint than three EMI shielding cable glands and easier operation of termination with shielded cable by a washer compressing the shield to the inside surface of the shell. The connector series covers 2 or 3 power contacts. As an example, one ePower 400A connector can replace three conventional connectors, saving space and cost.

ePower系列连接器是专为混合动力、电动车以及公共载重汽车电气系统的苛刻要求而设计的，其额定电压为800VDC到1000VDC，连续额定电流达到200A、400A和700A。它的大小比3个带EMI屏蔽的电缆格兰小40%，且接线（屏蔽电缆）操作更容易。ePower系列提供2或3芯的配置。

► | Features & Benefits 性能特点:

- Two or three circuit power
2~3条电路
- Crimp, lug or bus bar termination
接线采用压接、接线片或汇流排
- IP2X on pin and socket
公端和母端防触电设计 (IP2X)
- Environmental IP67 rating 防护等级IP67
- Two HVIL circuits 2条高压互锁电路
- 1,000vdc rating 额定电压: 1000vdc
- 5.7mm - 14mm RADSOK technology for 200 to 500A current capability
RADSOK端子尺寸5.7mm - 14mm，承载电流200A至500A
- Strain relief for jacketed cable incorporated into shell
自带护套电缆线夹
- Integrated EMI shielding 集成EMI屏蔽
- Excellent vibration resistance 优秀的抗震性
- All aluminum shell 全铝外壳结构

► | Receptacle 插座

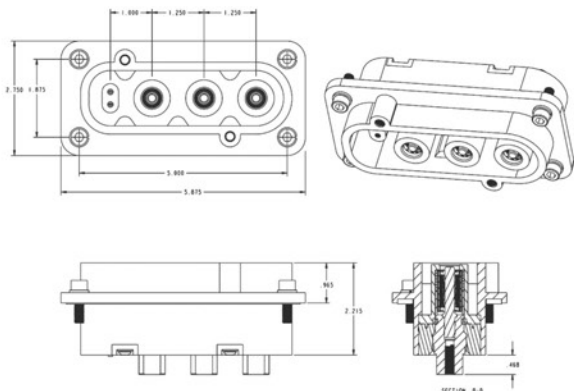

► | Plug 插头

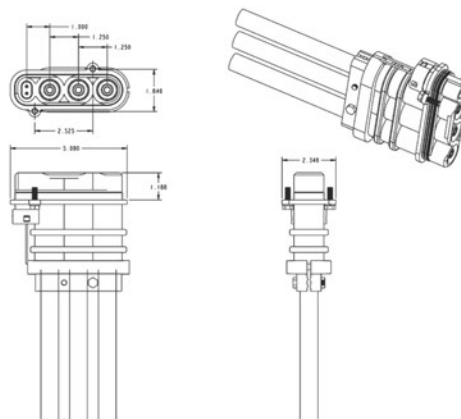

► | Ordering Information 订购选型指南

1	2	3	4	5	6	7							
e	P	2	2	25	1	1							
Product line 产品系列	Connector 连接器类型	Amp Level 电流(安培)	Number of Poles 芯数	Wire Size 接线类型/尺寸	KeY Position 键位	Platin9 电镀							
e	ePower	P	Plug 插头	2	200A	2	2 Pole 2芯	BB	Busbar (Receptacle Only) 汇流排 (仅插座)	1	Available in 2 & 3 Pole	1	Electroless Nickel 化学镀镍
		R	Receptacle 插座	4	400A	3	3 Pole 3芯	25	25 mm ² (200A Only)	2	Available in 2 & 3 Pole	FG	Tin over Nickel 电镀锡镍
								35	35 mm ² (200A Only)	3	Available in 2 & 3 Pole	B	No Plating 无电镀
								50	50 mm ² (200A or 400A)	4	Available in 2 & 3 Pole		
								70	70 mm ² (400A Only)	5	Available in 3 Pole Only		
								95	95 mm ² (400A Only)	6	Available in 3 Pole Only		
										7	Available in 3 Pole Only		
										8	Available in 3 Pole Only		

ePower-Lite 系列



The ePower-Lite is a plastic power connector series especially designed to be used in the electric vehicle market. There are 2-pole, 3-pole and 4-pole for options. The robust plastic shell can withstand high temperature up to 125°C and provides 360 degree EMI function and integrated HVIL contacts in the connectors.

ePower-Lite是一个专为电动车辆市场设计的塑料电源连接器系列。

配置有2芯、3芯和4芯结构。其坚固的塑料外壳最高可耐 125°C 高温，同时提供360度EMI屏蔽功能，并在连接器中配备了HVIL高压互锁端子。

► Features & Benefits 性能特点:

- **Plastic shell, light weight**
塑料外壳、重量轻
- **Compact design for space considerations with EV/HEV**
特别为有空间局限性的电动/混合动力车辆市场设计的紧凑结构
- **Secondary locking feature**
增加的副锁功能
- **Low mating/un-mating force**
低插拔力
- **Durability: 100 mating cycles minimum**
最少耐100次插拔
- **Water proof: IP67**
防水等级: IP67
- **Touch proof: IEC 60529**
防触电设计
- **Flammability: UL 94V-0** 阻燃标准
- **EMC optional** 电磁兼容 (选项)
- **HVIL optional** 高压互锁 (选项)
- **Adding secondary locking** 增加了二级锁
- **RoHS Compliant** 符合无铅标准

► 2-Pole Electrical Receptacle with HVIL & Shielding Shell 2芯带高压互锁和屏蔽电气插座

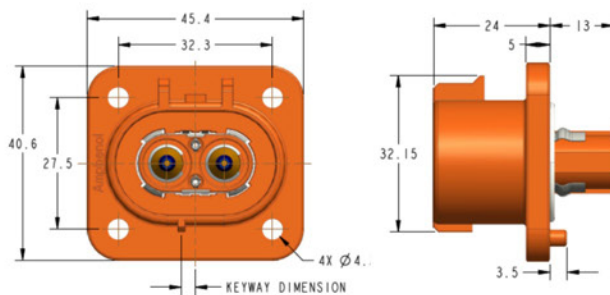

2芯插座面板开口尺寸

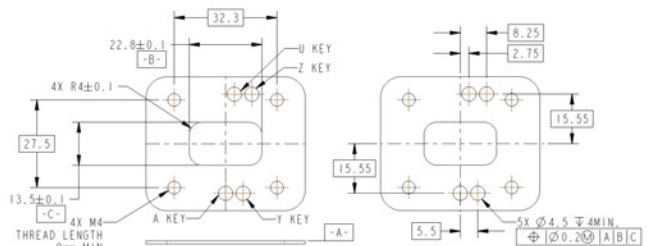

► 3-Pole Electrical Receptacle with HVIL & Shielding Shell 3芯带高压互锁和屏蔽电气插座

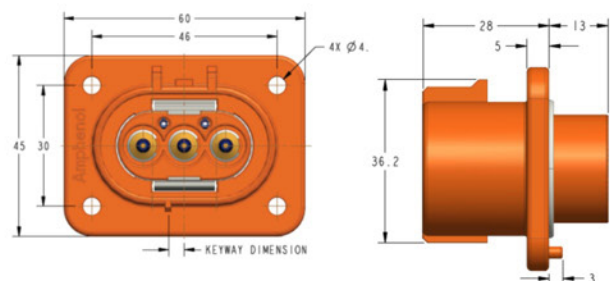

3芯插座面板开口尺寸

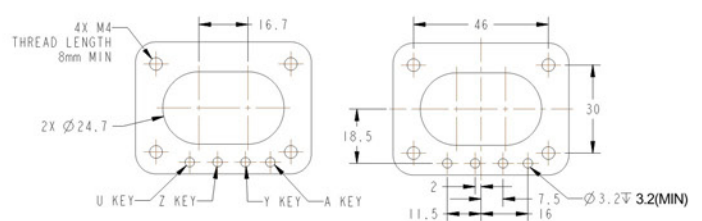

► | 4-Pole Electrical Receptacle with HVIL & Shielding Shell

4芯带高压互锁和屏蔽电气插座

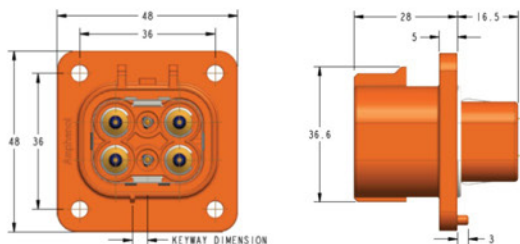

4芯插座面板开口尺寸

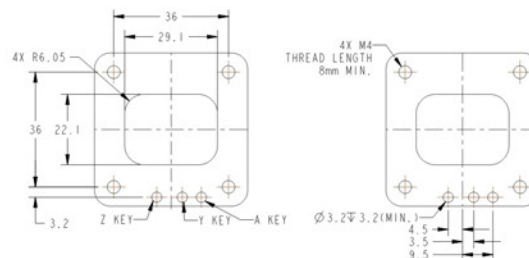

► | 2-Pole Electrical Plug with HVIL & Shielding Shell

2芯带高压互锁和屏蔽电气插头

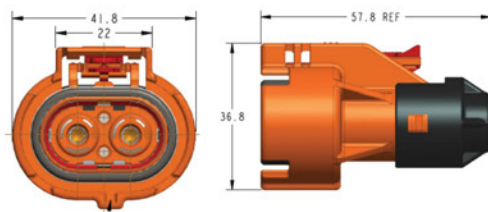

► | 3-Pole Electrical Plug with HVIL & Shielding Shell

3芯带高压互锁和屏蔽电气插头

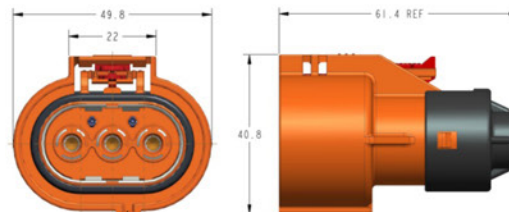

► | 4-Pole Electrical Plug with HVIL & Shielding Shell

4芯带高压互锁和屏蔽电气插头

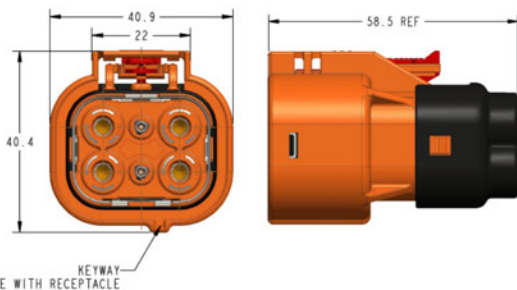

► | Key Marking 键位标志



Technical Data 技术参数				
Contact Test Current 端子测试电流	2-Pole 2芯	70 Amps/5 Amps	Test Voltage (Sea Level) 测试电压	3000V AC RMS
	3-Pole 3芯	70 Amps/5 Amps	Operating Temperature 工作温度	-40°C to 125°C
	4-Pole 4芯	70 Amps/13 Amps	Operating Voltage 工作电压	800V AC
Number of Contacts 端子数	2-Pole 2个	2&2	Finger Proof 防触电设计	IEC 60529
	3-Pole 3个	3&2	Durability 耐插拔	100(Min)
	4-Pole 4个	4&2	Water Proof 防水等级	IP67(Mated)
Contact Size 端子尺寸	2-Pole 2芯	3.6mm/#20	Salt Spray 盐雾测试	96H
	3-Pole 3芯	3.6mm/#20	HVIL 高压互锁	Yes
	4-Pole 4芯	3.6mm/#16	Recommended Torque 推荐扭矩	M4: 4~6N.M

► | Ordering Information 订购选型指南

Product Series 产品系列	Connector Type 连接器类型	Pole Number 芯数	Cross Mating Proof 防误插键位	Crimped Wire Size 压接线缆尺寸
EL	P Plug	2 2-Pole	A Key/A	01 2.5mm ²
	R Receptacle	3 3-Pole	Y Key/Y	02 4.0mm ²
		4 4-Pole	Z Key/Z	03 6.0mm ²
			U Key/U	04 10.0mm ²

UPT 系列



Based on the 26482 Series I, UPT is a plastic shell interconnect with a metal bayonet coupling system and crimp contacts. Featuring a light weight design, smaller footprint and easy field installation, the UPT is a cost effective industrial connector solution. The UPT provides more options for industrial interconnect markets that do not require a metal shell or Mil-Spec equivalents.

UPT连接器是基于26482 系列1标准开发的一款以塑料外壳、金属卡口连接螺母与压接端子为特色的连接器。UPT具有重量轻、体积小和易于现场安装的特点，是一款经济型的工业连接器。

UPT为不要求金属外壳或军标要求的工业电气连接市场中提供了更多的选择。

UPT06D-24-32S

Size 24, 32 Way, Plug 外壳#24, 32芯 插头

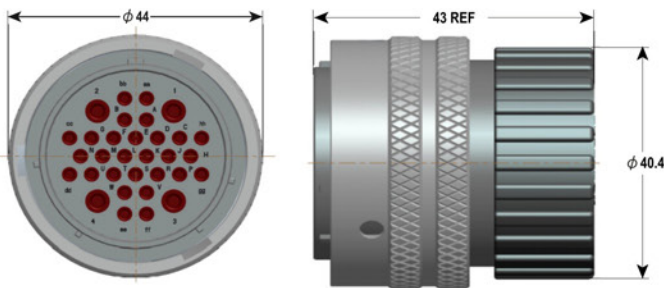

UPT07D-24-32P

Size 24, 32 Way, Jam nut Receptacle 外壳#24, 32芯, 锁紧螺母插座

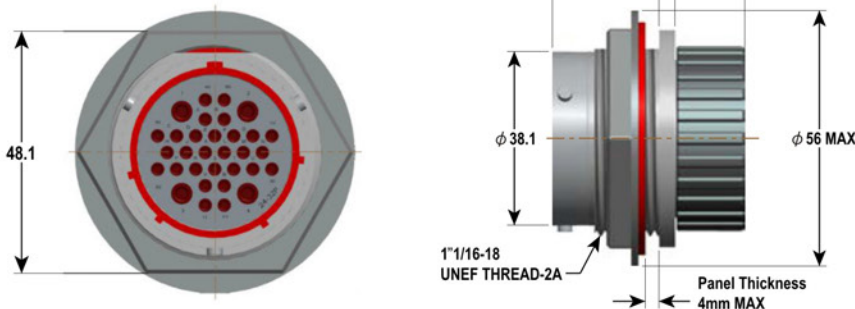

Features & Benefits 性能特点:

- Contact sizes and arrangements: 12 & 16 stamped & formed crimp contacts, two insert arrangements available (24-32 & 24-48)
端子尺寸和排布: 12 & 16号冲压成型压接端子, 2种排布方式 (24-32 & 24-48)
- Intermateable with Souriau TrimTrio, UTO, and ITT Trident Ringlock
可与Souriau TrimTrio, UTO和ITT Trident Ringlock 产品系列互配
- Wall mount, jam nut, and straight plug shell styles
外壳式样: 墙装式、锁紧螺母式、直插头式
- Plastic shell, light weight 塑料外壳、重量轻
- Metallic bayonet coupling, molded receptacle
金属卡口连接、模制插座
- Quick connect/Disconnect 快速连接/断开
- Multiple back shell sealing accessories
多种尾附件/密封选择
- ROHS compliant 符合无铅要求

Technical Data 技术参数

Rated Current Contact #16 16号端子额定电流	13 Amps
Rated Current Contact #12 12号端子额定电流	23 Amps
Operating Voltage 工作电压	250VAC
Withstanding Voltage 耐电压	2000V DC
Insulation Resistance 绝缘阻抗	5000 Megohms Min.
Operating Temperature 工作温度	-55°C~+125°C
Water Proof 防水等级	IP67(Mated)
Flammability 阻燃性	UL 94 V-0
Durability 耐插拔	500 Cycles (500次)

Front Face of Pin Illustrated

Insert Arrangement 端子排布	24-32	
Number of Contacts 端子数量	4	28
Contact Size 端子尺寸	12	16

Recommended cut-out 推荐面板开口尺寸

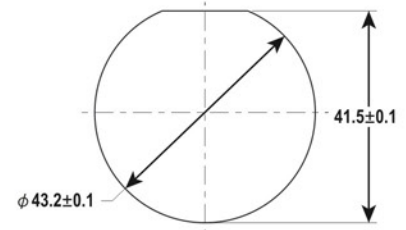

▶ **UPT00D-24-32P**
 Size 24, 32 Way, Wall Mounting Receptacle
 外壳#24 32芯 墙装式插座

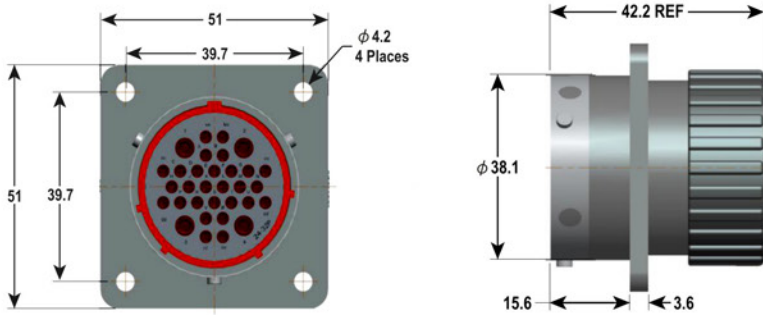

▶ **Recommended Cut-Out**
 推荐面板开口尺寸

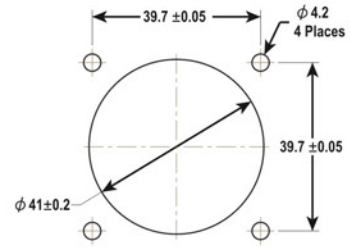

▶ **24 Size, 32 Way** 外壳#24, 32芯公端子

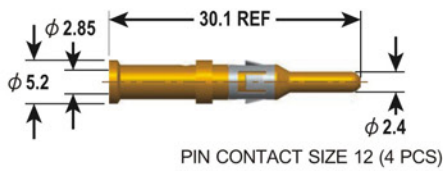

▶ **24 Size, 32 Way** 外壳#24, 32芯母端子

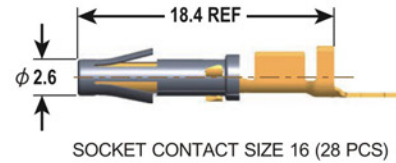
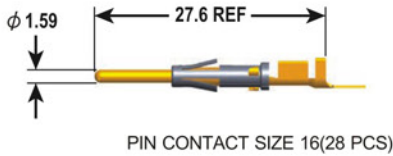
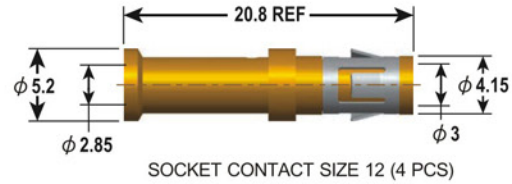

▶ **UPT06D-24-48S**
 Size 24, 48 Way, Plug 外壳#24, 48芯, 插头

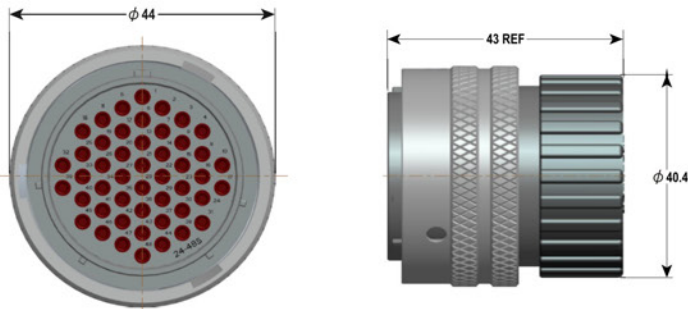

Front Face of Pin Illustrated	
Insert Arrangement 端子排布	24-48
Number of Contacts 端子数量	48
Contact Size 端子尺寸	16

▶ **UPT00D-24-48P**
 Size 24, 48 Way, Wall Mounting Receptacle
 外壳#24, 48芯, 墙装式插座

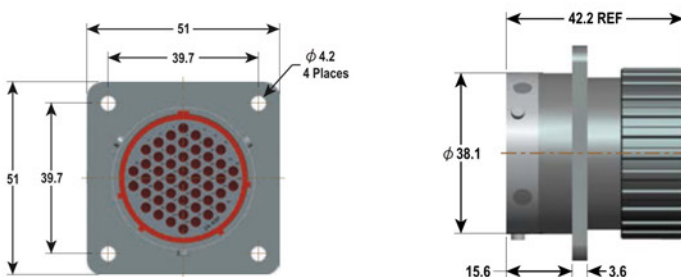

▶ **Recommended Cut-out**
 推荐面板开口尺寸

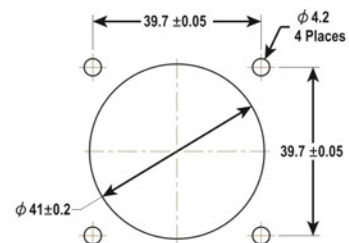

► | **UPT07D-24-48P**
Size 24, 48 Way, Plug 外壳#24, 48芯, 锁紧螺母插座

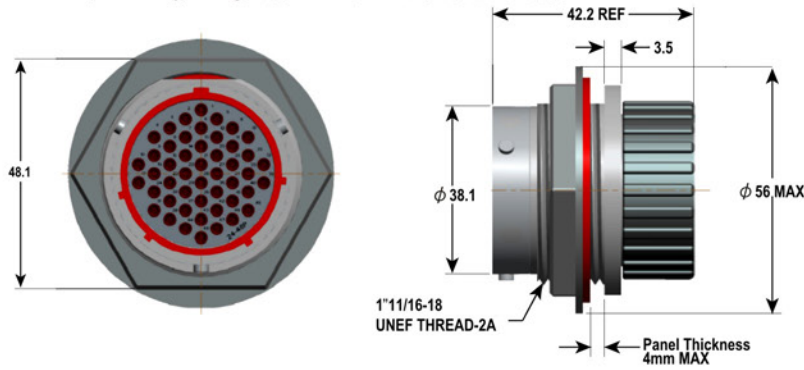

► | **Recommended Cut-out**
推荐面板开口尺寸

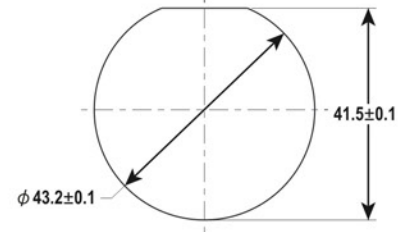

► | **24 Size, 48 Way** 外壳#24, 48芯
Pin Contact 公端子

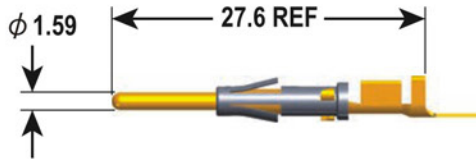

PIN CONTACT SIZE 16 (48 pcs)

► | **Socket Contact**
母端子

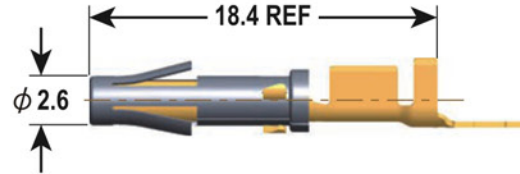

SOCKET CONTACT SIZE 16 (48 pcs)

► | **Ordering Information** 订购选型指南

Product Series 产品系列	Connector Type 连接器类型	Shell Type 外壳类型	Insert Pattern 芯模式		Contact 端子	Cross Mating Proof 防误配键位			Shell Plating 外壳电镀		Back Shell 尾附件		
			Shell Size 外壳尺寸	Contact Arrangement 端子排布									
UPT	06 Plug 插头	M MetalShell 金属外壳	10	4 Size 16 Contacts	P Pin (公端)	Omit	Normal key	Omit	Nickel Plating 48H salt spray 镀镍耐48小时盐雾	Omit	With grommet and nut 带密封垫圈和螺母		
			D Dielectric Shell (Plastic) 绝缘外壳 (塑料)	12	8 Size 16 Contacts	S Socket (母端)	W	Key/W	1	Black Zinc plating 96H salt spray 镀黑锌耐96小时盐雾	N	No rear accessory 无后附件	
				14	12 Size 16 Contacts		X	Key/X	2	Tin plating 720H salt spray for die casting 压铸件镀锡耐720小时盐雾			
				16	19 Size 16 Contacts		Y	Key/Y		(Zinc-Nickel plating only for aluminum alloy coupling nut) 电镀锌镍仅用于铝合金连接螺母			
				18	23 Size 16 Contacts		Z	Key/Z					
				22	35 Size 16 Contacts								
				24	48 Size 16 Contacts								
			24	32(4 Size 12 + 28 Size 16 Contacts)									

Product Series 产品系列	Connector Type 连接器类型	Shell Type 外壳类型	Insert Pattern 芯模式		Contact 端子	Cross Mating Proof 防误插键位			Shell Plating 外壳电镀		Back Shell 尾附件		
			Shell Size 外壳尺寸	Contact Arrangement 端子排布									
UPT	00 Wall Mounting Receptacle 墙装式插座	M MetalShell 金属外壳	10	4 Size 16 Contacts	P Pin (公端)	Omit	Normal key	Omit	Nickel Plating 48H salt spray 镀镍耐48小时盐雾	Omit	With grommet and nut 带密封垫圈和螺母		
			D Dielectric Shell (Plastic) 绝缘外壳 (塑料)	12	8 Size 16 Contacts	S Socket (母端)	W	Key/W	1	Black Zinc plating 96H salt spray 镀黑锌耐96小时盐雾	N	No rear accessory 无后附件	
				14	12 Size 16 Contacts		X	Key/X	2	Tin plating 720H salt spray for die casting 压铸件镀锡耐720小时盐雾			
				16	19 Size 16 Contacts		Y	Key/Y		(Zinc-Nickel plating only for aluminum alloy coupling nut) 电镀锌镍仅用于铝合金连接螺母			
				18	23 Size 16 Contacts		Z	Key/Z					
				22	35 Size 16 Contacts								
				24	48 Size 16 Contacts								
			24	32(4 Size 12 + 28 Size 16 Contacts)									

Flexible Busbars 柔性母排(汇流排)

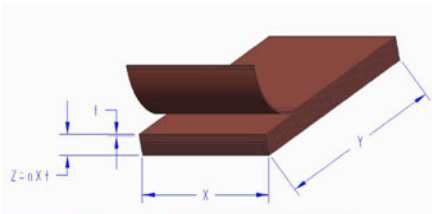

A	零件编号	t			
		n	X	t	
125 A	01	8	x 6	x 0.5	
	02	3	x 9	x 0.8	
	03	6	x 9	x 0.8	
	04	3	x 13	x 0.5	
	05	2	x 15.5	x 0.8	
250 A	06	9	x 9	x 0.8	
	07	6	x 13	x 0.5	
	08	4	x 15.5	x 0.8	
	09	2	x 20	x 1	
	10	3	x 20	x 1	
	11	2	x 24	x 1	
400 A	12	6	x 15.5	x 0.8	
	13	10	x 15.5	x 0.8	
	14	4	x 20	x 1	
	15	5	x 20	x 1	
	16	6	x 20	x 1	
	17	3	x 24	x 1	
	18	4	x 24	x 1	
	19	2	x 32	x 1	
	20	3	x 32	x 1	
	21	2	x 40	x 1	
500 A	22	5	x 24	x 1	
	23	6	x 24	x 1	
	24	4	x 32	x 1	
	25	3	x 40	x 1	
	26	4	x 40	x 1	
	27	3	x 50	x 1	
	28	10	x 20	x 1	
	29	8	x 24	x 1	
630 A	30	5	x 32	x 1	
	31	6	x 32	x 1	
	32	5	x 40	x 1	
	33	4	x 50	x 1	
	800 A	34	10	x 24	x 1
		35	8	x 32	x 1
		36	6	x 40	x 1
		37	5	x 50	x 1
		38	4	x 63	x 1
		39	3	x 80	x 1
40		10	x 32	x 1	
1000 A		41	8	x 40	x 1
		42	10	x 40	x 1
		43	6	x 50	x 1
	44	8	x 50	x 1	
	45	5	x 63	x 1	
	46	6	x 63	x 1	
	47	4	x 80	x 1	
	48	5	x 80	x 1	
1250 A	49	10	x 50	x 1	
	50	8	x 63	x 1	
	51	6	x 80	x 1	
	52	5	x 100	x 1	
	53	6	x 100	x 1	
	54	10	x 63	x 1	
1600 A	55	8	x 80	x 1	
	56	10	x 80	x 1	
	57	8	x 100	x 1	
	58	10	x 100	x 1	
	59	12	x 100	x 1	
	60	10	x 120	x 1	



► | Application 应用



► | How to Order

1		2		3		4		5
R	Rigid busbar	T	With shrink tube	BK	Black	D	ODM	Serial Number
F	Flexible busbar	NT	No shrink tube	RD	Red	E	OEM-need customer's drawing	01
				BU	Blue			02
				YE	Yellow			03
				GN	Green			...
				WH	White			60
				SP	Special colors			
				NA	None			

North America

Amphenol Industrial Product Group

191 Delaware Avenue

Sidney, NY 13838-1395 - USA

Telephone: 888-364-9011 Fax: 520-397-7169

www.amphenol-industrial.com

Asia

安费诺科技（珠海）有限公司

Amphenol Technology (Zhuhai) Co., Ltd.

地址：珠海市金湾区三灶镇二期科技工业园星汉路63号

Address: No.63, Xinghan Rd, Phase 2, Science and Technology

Industrial Park, Saozao Town, Jinwan, Zhuhai, PRC

电话/Tel: (86) 756-3989725 传真/Fax: (86) 756-3989768

www.amphenol-industrial.com



Notice: Specifications are subject to change without notice. Contact your nearest Amphenol Corporation Sales Office for the latest specifications. All statements, information and data given herein are believed to be accurate and reliable but are presented without guarantee, warranty, or responsibility of any kind expressed or implied. Statements or suggestions concerning possible use of our products are made without representation or warranty that any such use is free of patent infringement and are not recommendations to infringe any patent. The user should not assume that all safety measures are indicated or that other measures may not be required. Specifications are typical and may not apply to all connectors.